

NEW

TOURNEO CUSTOM



PROTM



Meet the new Tourneo Custom.

It's every bit the hard-working, reliable business partner you need. And it's every bit the technology-packed, spacious and comfortable family vehicle that's more than ready for your adventures.

THE SIMPLE WAY TO DRIVE A NEW FORD TOURNEO CUSTOM

1 EXPLORE

2 SELECT

3 CUSTOMISE

4 SPECIFICATIONS

5 PURCHASE

Vehicle shown features accessories.

Tourneo Custom Titanium L1 in Grey Matter premium body colour (option), shown with 19" multi-spoke alloy wheels in Luster Nickel (option).



1 EXPLORE

A STYLISH CHAMELEON

Full of brilliant ideas, the Tourneo Custom helps you make the most of work time and leisure time.

It's beautifully designed too. The vogueish appearance makes a great first impression on clients – and will impress your family just as much. Sitting on unique 19" alloy wheels*, the new Tourneo Custom looks like it means business. While the panorama roof** fills the cabin with light to make everyday travelling a joy.

It's also clever. Really clever. From intelligent safety systems, to connectivity, everything has been developed to be easy to use. Allowing you to concentrate on the day ahead.

*Option on Titanium only.
**Available on Luxe pack from Q2 2024.

Tourneo Custom Titanium L1 in Chrome Blue metallic body colour (option), with 19" multi-spoke alloy wheels in Luster Nickel (option).



1 EXPLORE

IT'S CLEVER. NOT COMPLICATED

The new Tourneo Custom has been designed to pander to your every need. First of all, Keyless Entry saves you from having to search your pockets or bag when approaching the vehicle, and is especially useful when carrying your morning coffee or loading antique furniture. You can even start the engine keylessly.

Inside, our designers have concentrated on creating a light and relaxing ambience that's complemented by premium textiles. The new 13" touchscreen puts everything you need within easy reach – while the intuitive Voice Control System helps make it all very simple to operate.

The latest SYNC 4 system provides essential information and navigation tools, and allows you to enjoy your favourite entertainment through the sound system. Plus, you can wirelessly connect your Apple or Android smartphone, allowing you to keep up to date with business orders or evening plans with ease.

*The AGR quality cachet (Aktion Gesunder Rücken = Campaign for Healthier Backs): Certified and recommended by Association Forum Healthy Back – Better Living and Federal Association of German Back Schools. More information: AGR e.V., Stader Str. 6, D - 27432 Bremervörde, Phone + 49 4761/926 358 0.

Tourneo Custom Titanium L1 with Black Onyx trim (standard), shown with Ford SYNC 4 (standard).

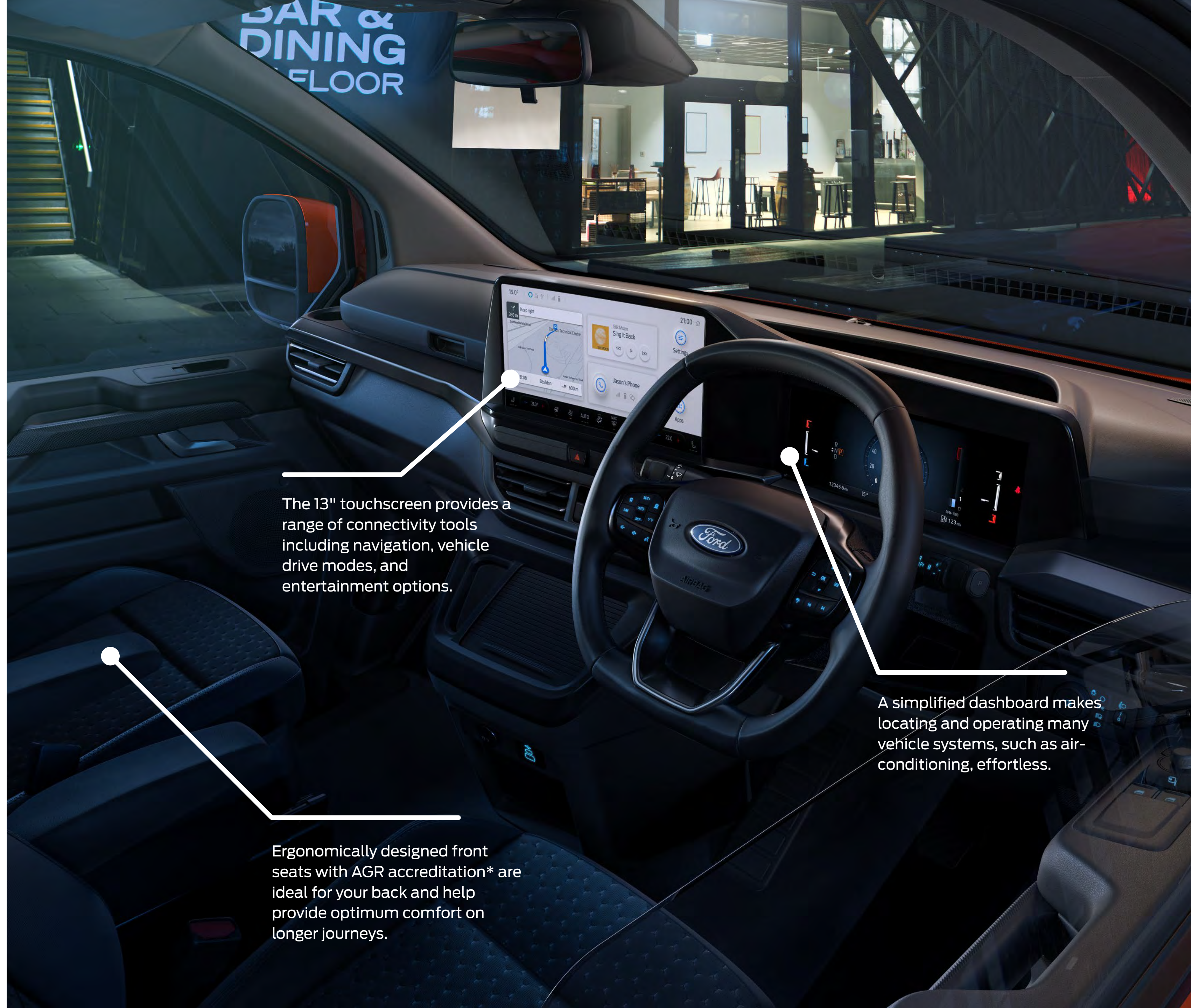

The 13" touchscreen provides a range of connectivity tools including navigation, vehicle drive modes, and entertainment options.

A simplified dashboard makes locating and operating many vehicle systems, such as air-conditioning, effortless.

Ergonomically designed front seats with AGR accreditation* are ideal for your back and help provide optimum comfort on longer journeys.

1 EXPLORE

SPACE TO THRIVE

Built on an all-new platform, your Tourneo Custom delivers both impressive and improved proportions as well as expressive styling – all of which combine to make life uncomplicated.

A lower step-in height makes entering and exiting the vehicle a more elegant experience for both driver and passengers. While the electric parking brake (EPB) and column-mounted auto shifter makes moving around and across the front of the cabin squeeze-free.

Getting in and out of a garage – at home or business premises – is now even easier too. The overall height of the vehicle has been reduced by 50 mm, making it less than two metres tall.

And once you're in, it's time to enjoy the refined ride. The new driving position gives the Tourneo Custom a more car-like feel, while maintaining excellent levels of visibility.

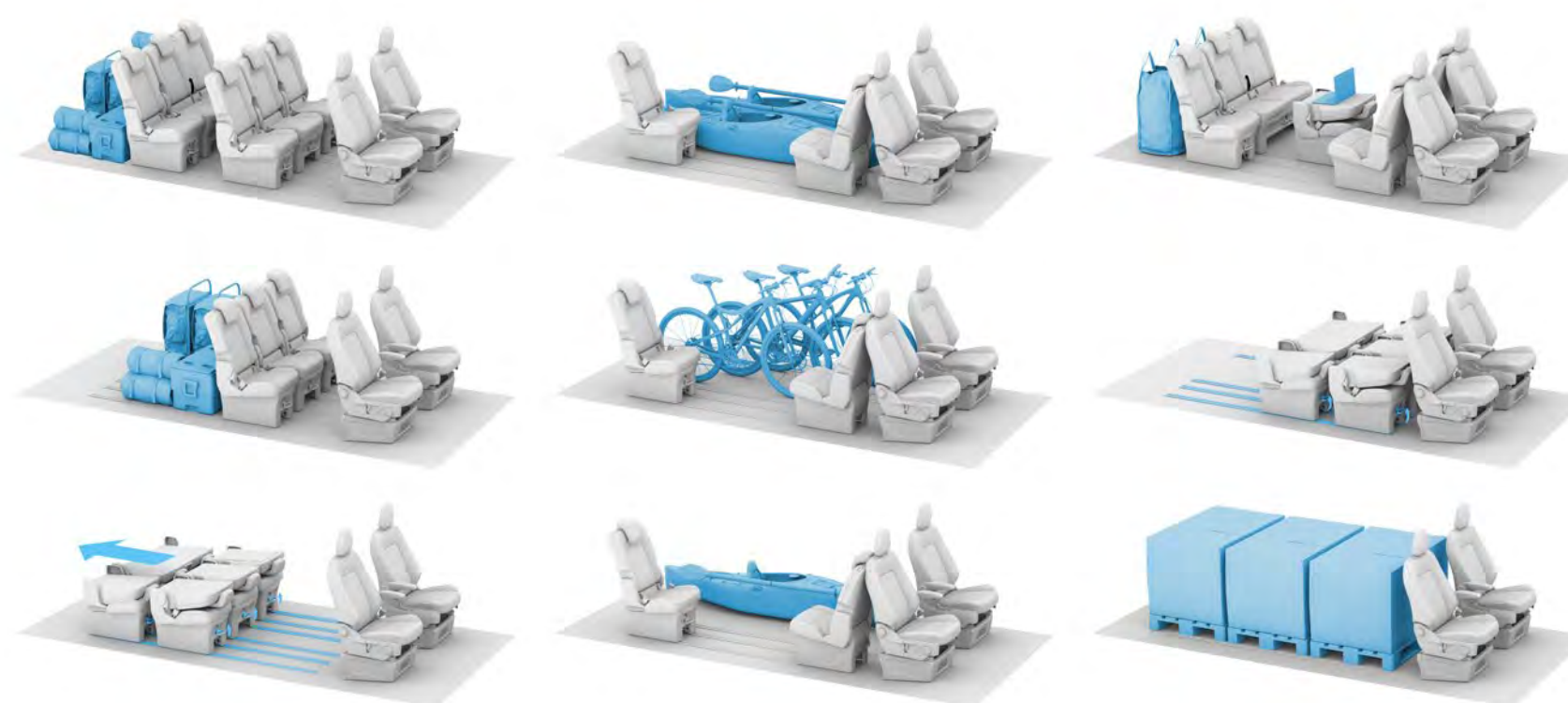

Tourneo Custom Titanium L1 in Grey Matter premium body colour (option), shown with Barlo Pin Hex Emboss in Medium Urban Grey (option).



PERFECTLY COMPOSED

The passenger compartment of the new Tourneo Custom is a great place to be. If passengers are travelling for business, the seats can be easily arranged into conference mode, which allows up to six people to face one another. The middle seat in the second row can also be folded flat to create a conference table for accommodating laptops or drinks. If you're travelling for leisure, the track system allows seats to be moved or removed quickly. So whether you need to carry the kids plus their bikes and even a canoe for a weekend adventure or you need to fit in a chair you spotted at the antiques market, your new Tourneo Custom is ready for anything.



9 seater L1 H1 configuration

The second row provides three individual seats and a 2+1 configuration in the third row. A track length of 1,816 mm allows passengers to enjoy ample room in both front-facing and conference mode seating arrangements.



9 seater L2 H1 configuration

An extended track length of 2,216 mm provides additional legroom or the ability to carry extra luggage.

Tourneo Custom Titanium L2 in Artisan Red metallic body colour (option), shown with Barlo Pin Hex Emboss in Medium Urban Grey (option).



BUILT FOR BIG CHALLENGES

Tourneo Custom now offers the reassurance of all-wheel drive. From rainy roads to off-road camping trails, as well as snow and ice, the system gives the vehicle greater grip and allows you to get the power down confidently when needed. To help best suit your business and lifestyle needs, all-wheel drive is available with a choice of refined diesel engines, including an economical 136 PS automatic or a more punchy 170 PS 8-speed automatic.

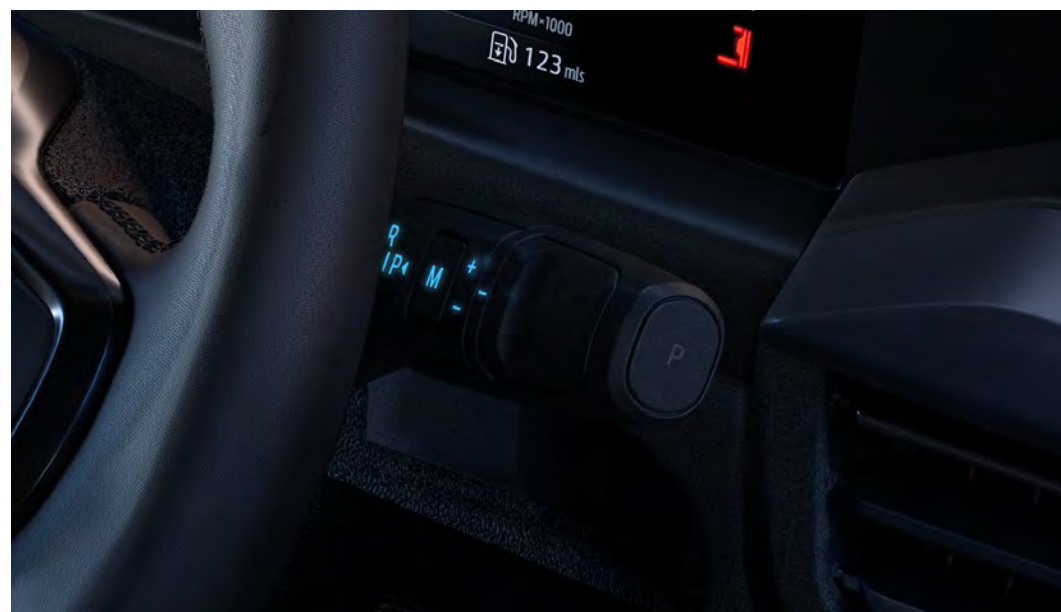

8-speed automatic transmission

Delivers power smoothly across the range to help optimise day-to-day economy, and to give you extra oomph when it's needed.



Fixed tow bar

Ideal for towing large items of up to 2.5 tonnes (max.)*, the optional tow bar is designed to be fully compatible with the vehicle's electrical system.

*Even when towing the gross train mass (GTM) must not be exceeded. Vehicle shown features accessories.

Tourneo Custom Titanium L1 AWD in Artisan Red metallic body colour (option), shown with 19" multi-spoke alloy wheels in Luster Nickel (option).





1 EXPLORE

SERIOUS ABOUT SECURITY

Ford knows your van is your livelihood. Which is why we've put multiple systems in place that, when enabled, alert you if the vehicle is being tampered with or is not where it should be.

Incline Alerts* detect if the vehicle has been jacked or lifted while the ignition is off.

Impact Alerts* notify you if a vehicle has been on the receiving end of a detectable impact when parked.

Inconsistent Location Alerts* monitors for location changes between vehicle turn off and next ignition.

Security Alerts*† notify you if a door has been opened when it shouldn't have been.

A range of optional security solutions and packs are also available including a Slam Handle, and Hook Locks with and without deadlocks, as well as Armourshells and Anti-Pick Locks.

*Requires a Ford Telematics subscription. †Available with FordPass Pro and FordPass.

DIESEL POWER

From power and torque to efficiency and refinement, each engine in the Ford EcoBlue diesel range has been optimised to meet your most demanding needs and the stringent Euro 6.2 emissions standards. A range of fuel-saving technologies that include*, low rolling resistance tyres and an 8-speed automatic transmission help offer greater efficiency than ever before.

EFFICIENT

2.0L Ford EcoBlue 136 PS diesel engine

Offering outstanding fuel efficiency (from 7.4L/100 mi combined) with excellent driveability and refinement, without loss of payload capability or performance.



136 PS, 100 kW, TBC Nm
From 193g/mi**

FLEXIBLE

2.0L Ford EcoBlue 150 PS diesel engine

Striking a balance of delivering the extra power and torque necessary to enhance gross train mass (GTM), without compromising emissions. (Manual only)



150 PS, 110 kW, TBC Nm
From 193g/mi**

POWERFUL

2.0L Ford EcoBlue 170 PS diesel engine

The most powerful engine in the range. Its hardworking character makes it ideal for moving heavy loads and towing, while delivering outstanding fuel efficiency. (Automatic only)



170 PS, 125 kW, TBC Nm
From 210g/mi**

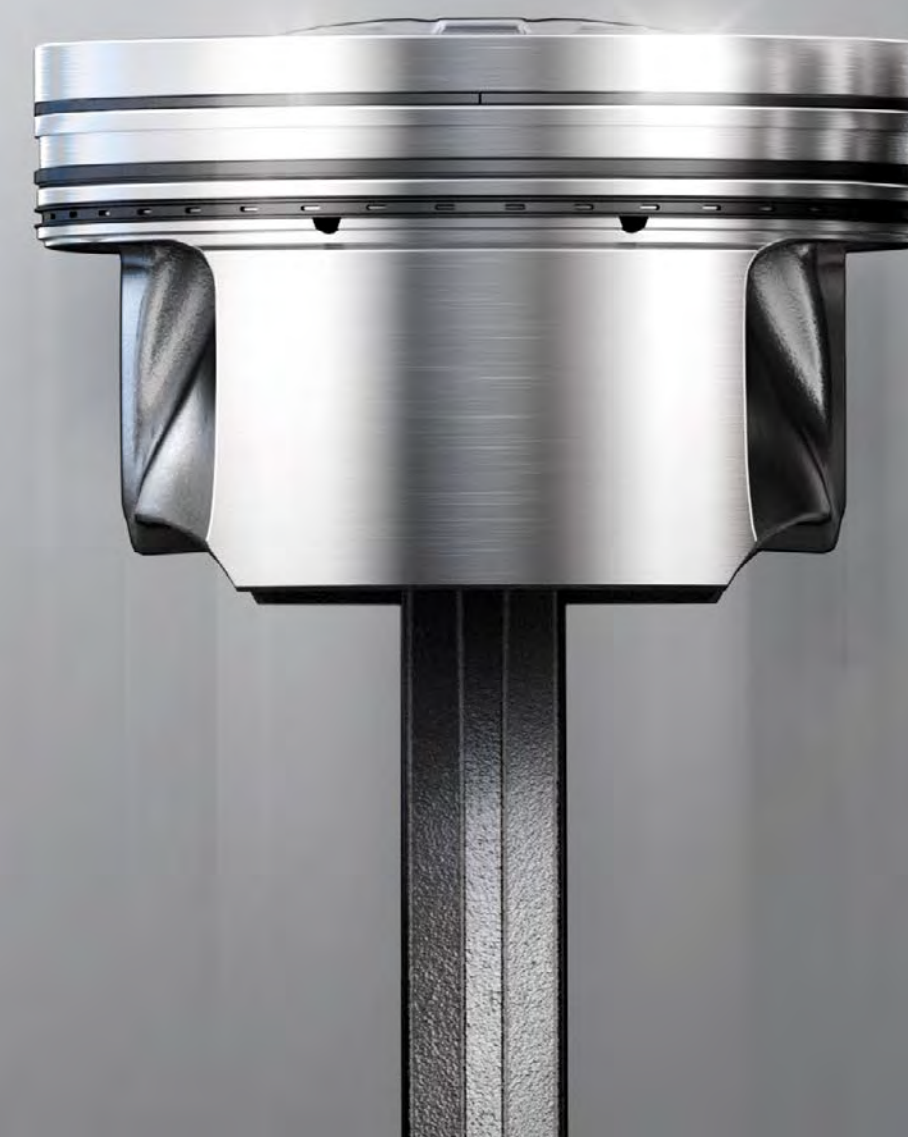

*Some of the features listed above are options, at extra cost and may not be available on all models. Please refer to the specification tables or speak to your Ford Commercial Vehicle Dealer for further information.

**WLTP figures. For more information, please see Fuel and Performance section.

Note For further fuel economy and emissions information, please refer to the specifications section.

1 EXPLORE

SELECTABLE DRIVE MODES

A choice of drive modes includes, Normal, Eco, and Slippery. The system adjusts various settings, including throttle response, helping make driving easier in certain conditions.



PANORAMA ROOF^{††}

Let light flood the cabin and brighten everyone's mood during the day or let your passengers enjoy city lights and stars with this tinted panorama roof.

^{††}Available on Luxe pack from Q2 2024.

LED HEADLIGHTS

Tourneo Custom is eye-catching from every angle, and none more so than the front. LED headlights offer the added reassurance of automatic high-mounted headlights to provide excellent illumination in all conditions. While LED daytime running lights give a more stylish and dynamic look.



TRI-ZONE AUTOMATIC ELECTRONIC TEMPERATURE CONTROL

The new Tourneo Custom allows everyone to travel in comfort. Both driver and front passenger can regulate the temperature to be exactly how they like it in their zone, and in the rear of the vehicle passengers can choose their own setting.

1 EXPLORE

KEYLESS START

When you take your seat, there's no need for an ignition key. Simply depress the clutch (or depress the brake on auto), push the Ford Power starter button and you're ready to go. (Standard)



ELECTRIC PARKING BRAKE

Just like a premium vehicle, a simple switch in the middle of the console allows you to effortlessly apply the parking brake without having to reach. Not only is it ideal for when stopping in tighter spots and you can't risk rolling forwards or backwards, but it also creates more space in the cabin.

KEYLESS ENTRY

Walk towards your Tourneo Custom and the Ford KeyFree System senses the presence of your key fob (even if it's in your pocket or bag), and unlocks all doors. (Standard)



1 EXPLORE

SYNC 4

New to Tourneo Custom, SYNC 4 intuitively connects to your world through a striking 13" landscape display. Wireless Apple CarPlay and Android Auto* give you seamless access to your music, and maps, as well as some of your favourite apps. The system can be conveniently controlled via a hand gesture or hands-free Voice Control, allowing you to more safely dictate text messages or to speak to family, friends or work mates.

Connected Navigation† (optional subscription, and complimentary for the first 12 months**) allows you to more effectively plan your journey. Enjoy all the benefits of real-time traffic updates, weather information as you go, fuel-stops and their prices, as well as parking availability at your destination.

Ford Power-Up updates keep your vehicle's systems evolving by wirelessly upgrading the software – improving functionality without interrupting your day.

Note Navigation is available with selected Driver Assist packs on all vehicles with SYNC 4.

Note Full SYNC 4 smartphone integration is only available with iPhone 5/Android 5.0 (Lollipop) or higher. Some SYNC 4 functions require a data connection, so mobile data charges will apply. To check whether Apple CarPlay and Android Auto are available in your market, please check their official websites for the latest information.

*Don't drive while distracted. Use voice-operated systems when possible; don't use handheld devices while driving. Some features may be locked out while the vehicle is in gear. Not all features are compatible with all phones.

†Following the initial 12-month Connected Navigation trial period a subscription fee is payable. Connected Navigation uses connected vehicle data (such as driving and location data) shared through the FordPass Connect. Data sharing with Ford can be managed through the in-vehicle settings, but this may impact the services available.

**From warranty start date.



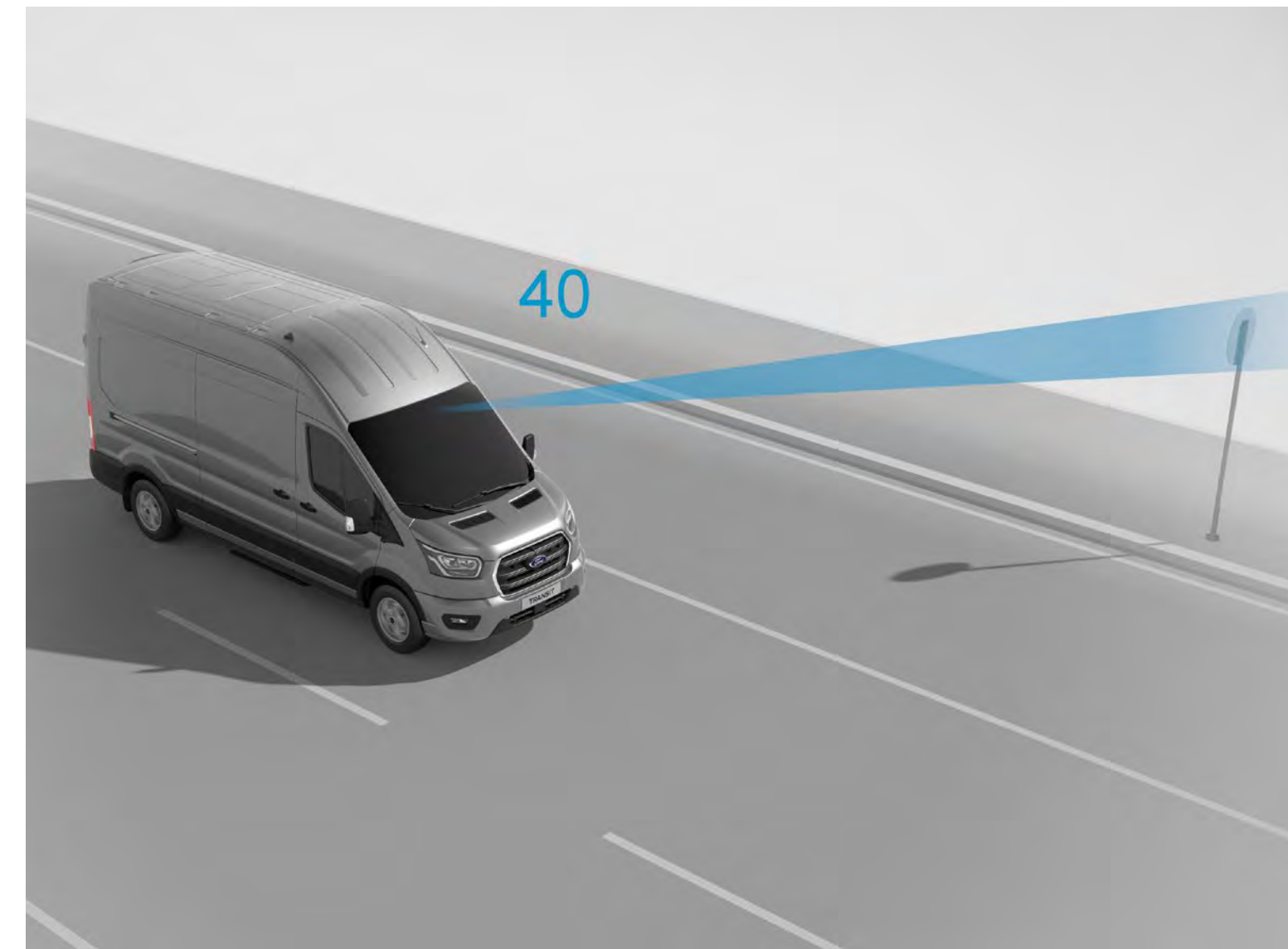
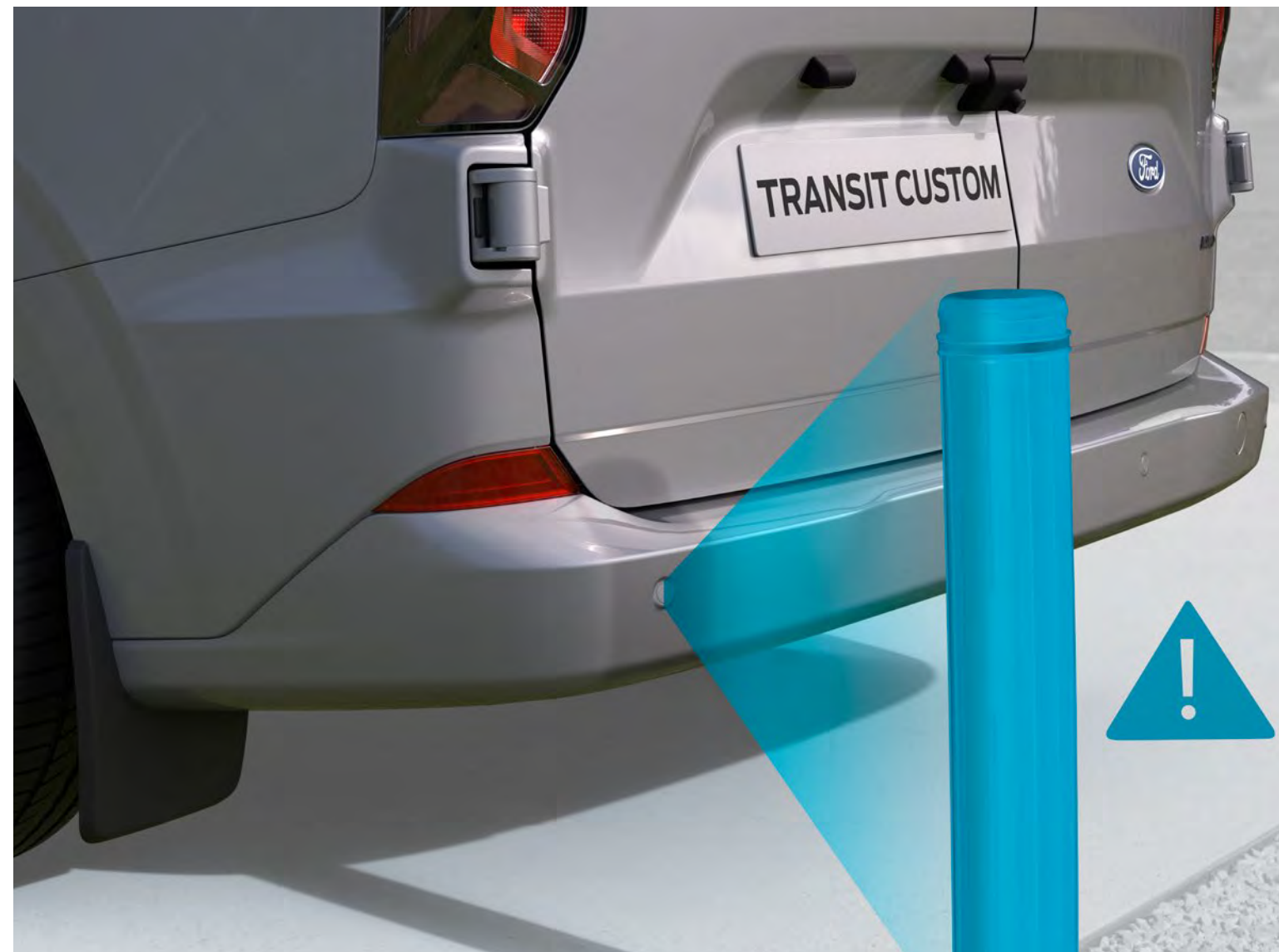
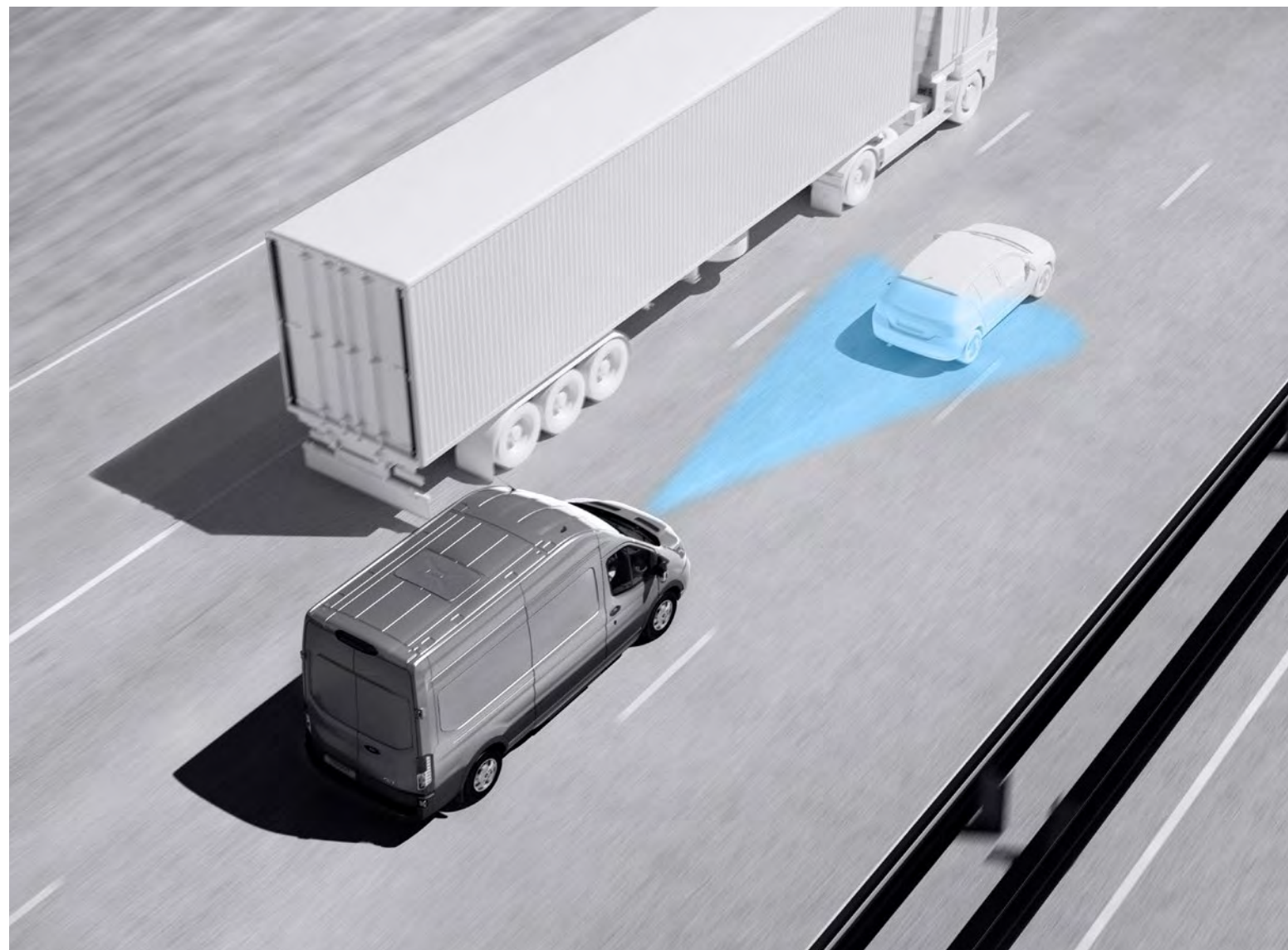

INTELLIGENT ADAPTIVE CRUISE CONTROL⁰¹⁾

Tourneo Custom can help take the stress out of heavy traffic. Intelligent Adaptive Cruise Control⁰¹⁾ (option) uses satellite navigation information combined with Traffic Sign Recognition⁰¹⁾ to identify the prevailing speed limit. The system can then automatically adjust your vehicle's speed to keep you within the limit detected.

FRONT AND REAR PARKING DISTANCE SENSORS⁰¹⁾

The Tourneo Custom is a great looking vehicle, and we want to help you keep it looking that way. The front and rear parking sensors assist you when judging the distance between your vehicle and any obstacles. And when the sensors detect an object, an audible warning is activated, which gets increasingly louder the closer you get. (Standard)

TRAFFIC SIGN RECOGNITION⁰¹⁾

Whether the signs are at the side of the road or above it, permanent or temporary, Traffic Sign Recognition⁰¹⁾ can identify them. An icon of that speed or no-overtaking sign appears on the instrument cluster and changes every time you enter a new limit, keeping you fully informed on every journey.

⁰⁾Uses sensors. ¹⁾Driver Assistance feature. **Note** Driver-assist features are supplemental and do not replace the driver's attention, judgement and need to control the vehicle.

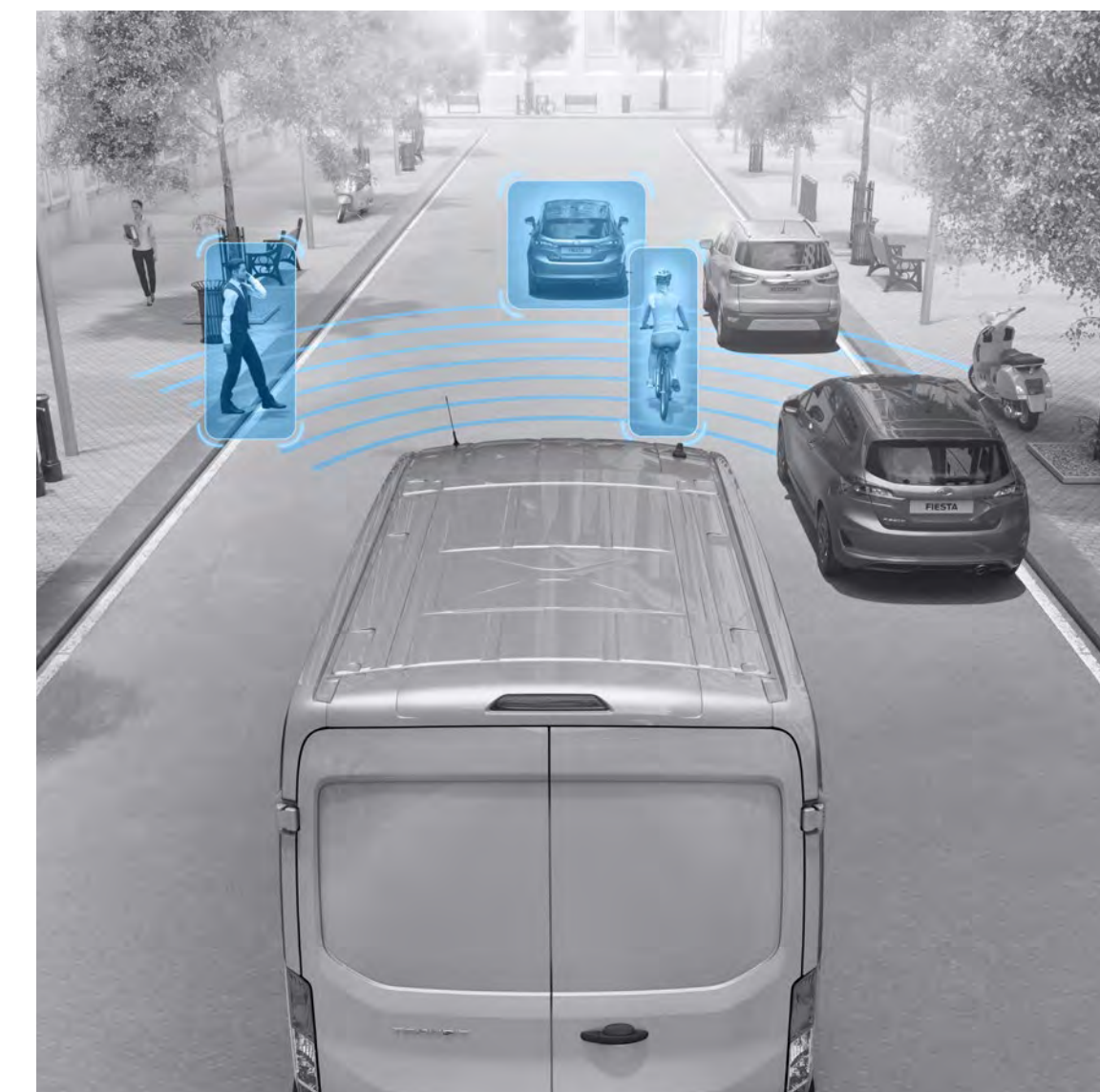
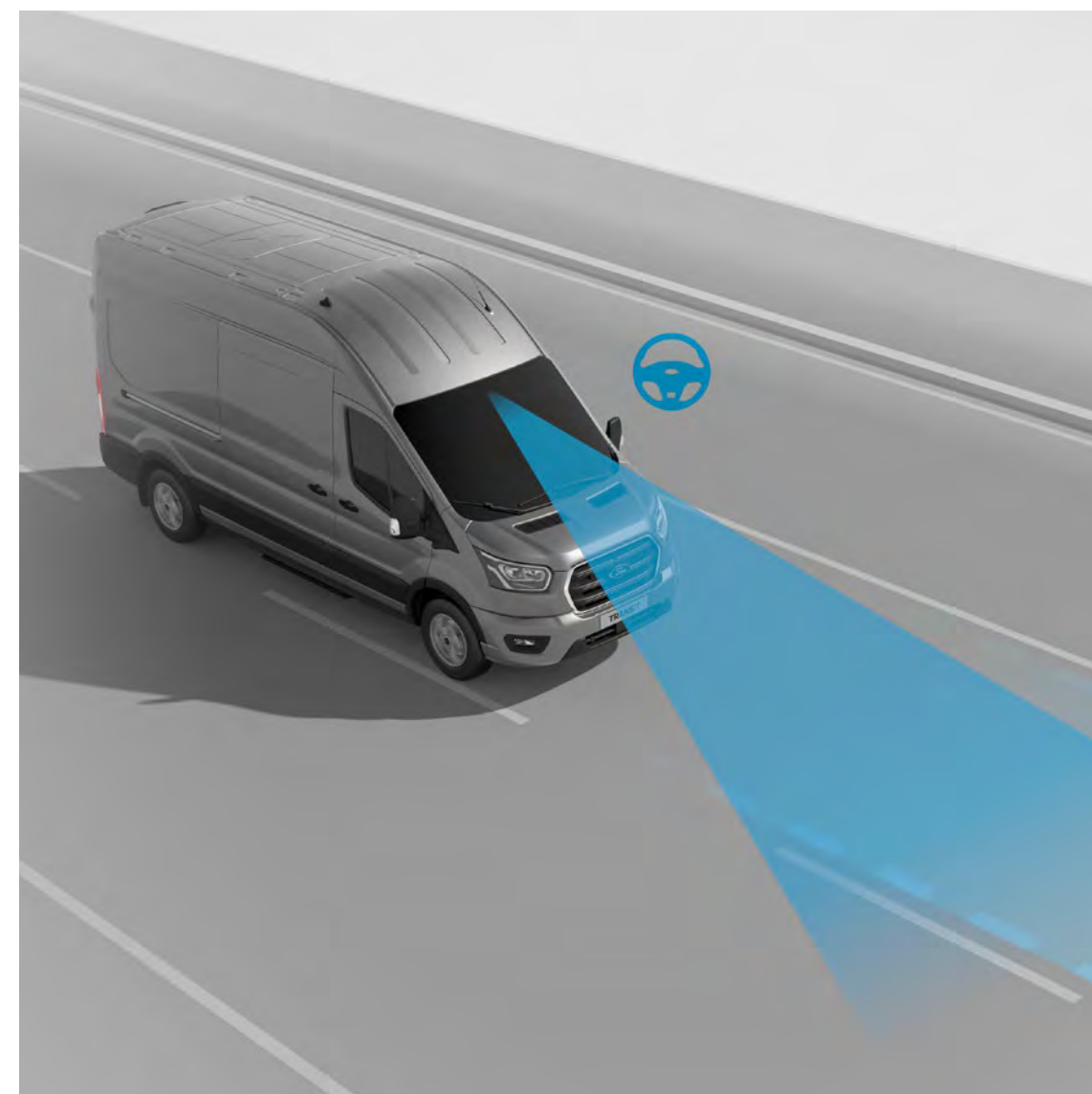
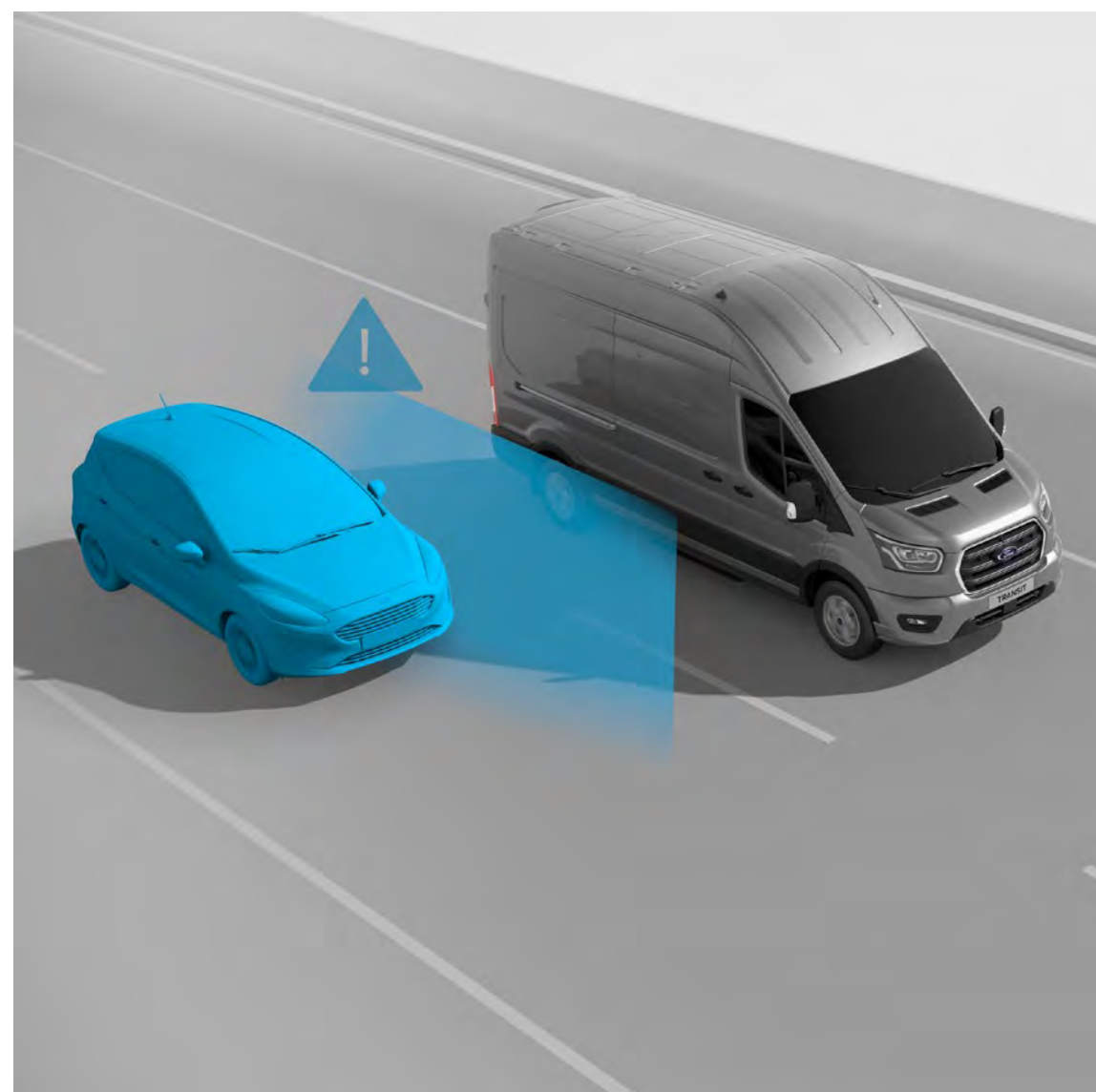

ELECTRONIC STABILITY CONTROL (ESC)⁰²⁾

When you deviate from your chosen line the system aims to keep you on track by automatically regulating braking and engine output. Traction Control⁰²⁾ also helps eliminate excessive wheelspin to optimise grip. (Standard)

BLIND SPOT INFORMATION SYSTEM⁰²⁾

Be warned when you begin a manoeuvre and a vehicle has entered or is entering your blind spot – the system will then proceed to guide your vehicle back into the host lane. (Option)

LANE-KEEPING SYSTEM⁰²⁾

When you approach lane markings without using the indicator a warning is signalled through the steering wheel, and if you fail to react, Lane-Keeping Aid⁰²⁾ will apply steering torque to help keep you safely within your marked lane. (Standard)

INTERSECTION ASSIST WITH PEDESTRIAN DETECTION⁰²⁾

This system can monitor your proximity to other vehicles and pedestrians and can alert you audibly and visually if a potential collision is detected. While Active Braking⁰²⁾ can automatically apply full braking to help mitigate the effect of any impact or avoid the collision. (Standard)

⁰⁾Uses sensors. ²⁾Safety feature.

1 EXPLORE

FORD TELEMATICS ESSENTIALS

Ford Telematics Essentials[†] is a complimentary web-based fleet management tool which utilises a wealth of powerful data, including vehicle health status, to help you optimise uptime.

Designed for fleets of any size, it allows for more effective maintenance planning. And with access to FORDLive included, you can also share data directly with your Dealer for smarter, faster repairs.



Complimentary and connected

An ideal tool for medium to large fleet operators, it allows you to monitor the day-to-day essentials without charge. Available for all vehicles with a FordPass Connect modem.



Unlock health data

From manufacturer diagnostic codes with suggested actions and recall information, to customised maintenance schedules based on oil life, engine hours, time and mileage, you can identify issues before they become problems, and keep your fleet moving.



Connect to FORDLive

When you grant permission, your Ford Authorised Repairer can see your vehicle health data, allowing the Dealer to proactively order parts, flag other upcoming maintenance, and agree with you the best schedule to maximise uptime.

[†]Ford Data Services and Ford Telematics are available for Ford vehicles with a FordPass Connect modem or a Ford plug-in modem. Fleet/business customers only. Subscription charges and Ford Connected Service terms and conditions apply.

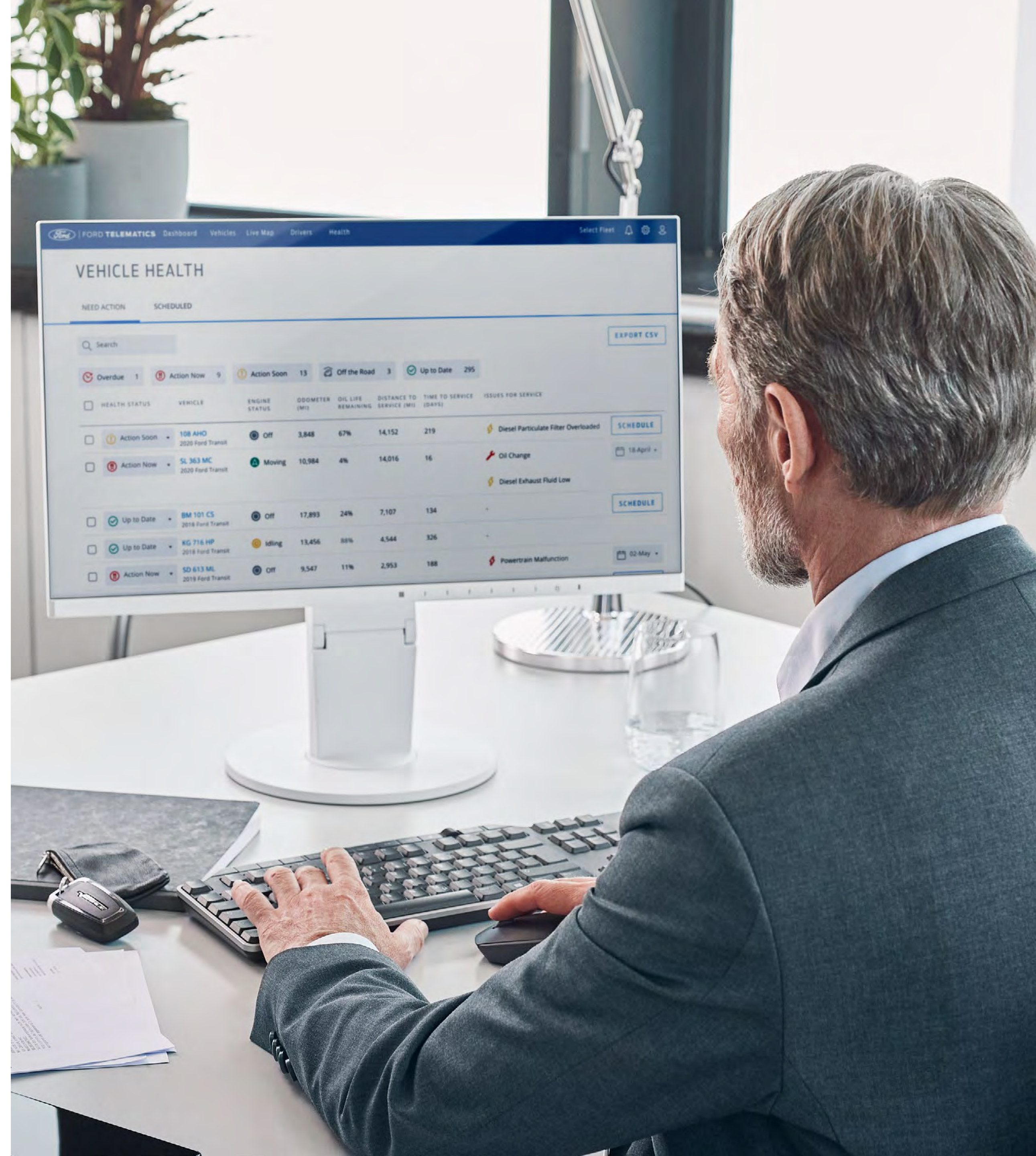

1 EXPLORE

FORD TELEMATICS

Available for fleets of any size, this range of productivity tools, alerts and vehicle insights, allows you to monitor your vehicles' performance, keep track of where they go, how they're used, and how they're running.



Improve asset utilisation

Keep track of the vehicles in your fleet with GPS tracking and geofencing capabilities. Knowing exactly where all vehicles are at all times helps you plan more effectively, and get the most out of your team.

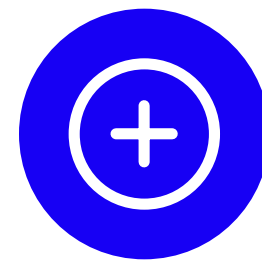

Maximise vehicle availability

Receive proactive notifications and vehicle health alerts, so you can plan ahead and stay ahead. Workflow tools help schedule services in advance, avoid costly, unexpected repairs, and reduce disruption to your operation.

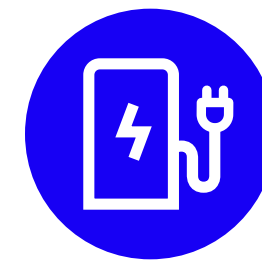

Optimise your running costs

With the ability to monitor fuel/energy consumption across your vehicles, you can identify areas of waste, and the causes – enabling you to improve efficiency, which can help you save money over the life of your vehicles.



Protect your fleet

Manage your fleet and driver compliance every day. You can receive a range of notifications, including advance service reminders, or a warning if a driver isn't wearing their seat belt. This helps you act quickly to protect your operation.



Improve driver behaviour

Your drivers play a key role in your operation, which is why Ford Telematics now includes in-vehicle coaching. The system also provides valuable insights into driver behaviour; and informs you of coaching opportunities to increase efficiency, reduce waste, and improve compliance.



Always stay informed

We also offer the Ford Telematics Drive app, which enables drivers to pair with a vehicle in your fleet. Drivers provide timely information about the roadworthiness of that vehicle to the fleet manager, by completing vehicle checklists, or by reporting any maintenance issues, all via the app.

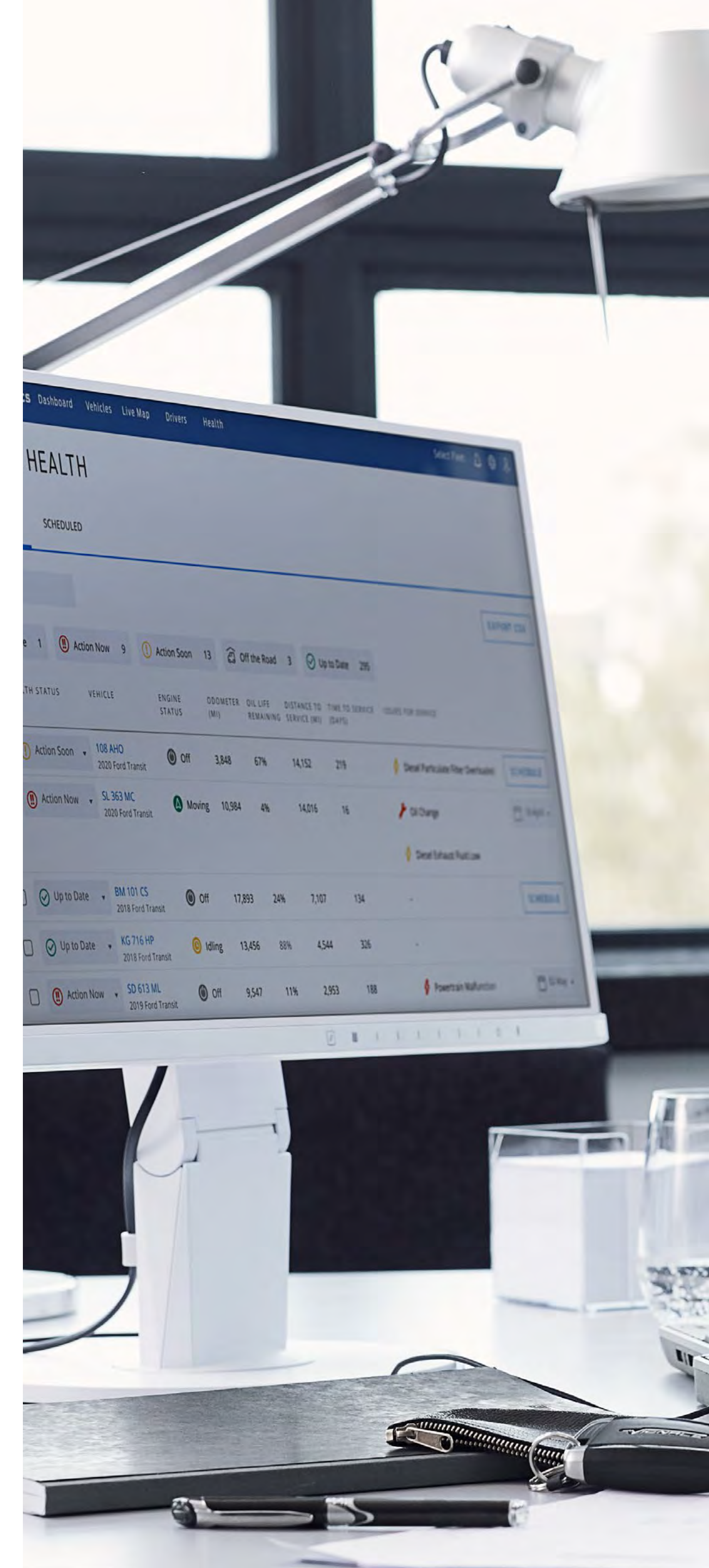

1 EXPLORE

FORDPASS PRO

Whether you work with one business vehicle or manage up to five, FordPass Pro gives you the tools you need to help keep them healthy, secure, and running smoothly. Simply download FordPass Pro from the App Store or get it on Google Play.



Health alerts

Receive notifications for key vehicle health information, such as oil life and tyre pressures.



Fleet health on map

Check the location and health status of all your vehicles on a single map at the start and end of the working day.



Remote Start

Ideal for cold and frosty mornings, Remote Start allows you to fire up the engine and defrost the windscreen before your working day.



Remote lock and unlock

Check if a vehicle is secure, plus lock or unlock it remotely – including separate Zonal Unlocking for cabin and load doors.



SecuriAlert

Offers a heightened state of security beyond your vehicle's alarm system. If someone is detected accessing your vehicle, even with a stolen or duplicated key, you will be notified.



Roadside Assistance

Keep your fleet up and running with Roadside Assistance when and where you need it (only available with an active Roadside Assistance plan).



Online service booking

Check your Dealer's availability and book your service directly through the app.



2 SELECT

Available in a range of lengths, with multiple interior configurations and personalisation options, as well as engine choices, finding the right vehicle for your lifestyle couldn't be easier.



Zetec

With premium textiles and features as standard, Zetec offers Black Onyx trim, a 13" touchscreen with SYNC 4, Keyless entry and Keyless Start, as well as 16" Sparkle Silver alloy wheels.



Titanium

Our most well-appointed series includes 17" twin-spoke Carbonised Grey alloy wheels, and features premium trim in Black Onyx, and offers a higher level of driver assistance technologies, as well as independent rear air conditioning.

2 SELECT

SERIES

ZETEC

Key exterior features

- 16" alloy wheels in Sparkle Silver with locking wheel nuts
- LED headlights with daytime running lights
- Front and rear parking distance sensors
- Rain-sensing front wipers
- Keyless entry
- Dual automatic power-foldable heated signal mirrors
- Fixed rear-view camera

Key interior features

- Quickclear heated windscreen
- Electric parking brake
- Keyless Start
- Intelligent Speed Assist
- Rear reading lights
- Automatic air conditioning
- Track based rear seating system
- Adaptive Cruise Control
- Sunblinds

Engines/Motors

Diesel

- 2.0L Ford EcoBlue 136 PS (100 kW) Manual FWD
- 2.0L Ford EcoBlue 150 PS (110 kW) Manual FWD
- 2.0L Ford EcoBlue 170 PS (125 kW) Automatic FWD
- 2.0L Ford EcoBlue 170 PS (125 kW) Automatic AWD



Ford SYNC 4 with 5G embedded modem, navigation and 13" touchscreen display

Sensico®-wrapped steering wheel

4-way adjustable driver's seat with lumbar support

2 SELECT

SERIES

TITANIUM

Key exterior features in addition to Zetec

- 17" twin-spoke alloy wheels in Carbonised Grey with locking wheel nuts
- Rear privacy glass
- Body colour front and rear bumpers

Key interior features in addition to Zetec

- 4-way adjustable driver's seat with lumbar support and adjustable armrests
- 4-way adjustable passenger's seat with lumbar support and inboard armrests
- Rear seat climate control
- Heated seats

Engines/Motors

Diesel

- 2.0L Ford EcoBlue 136 PS (100 kW) Manual FWD
- 2.0L Ford EcoBlue 150 PS (110 kW) Manual FWD
- 2.0L Ford EcoBlue 170 PS (125 kW) Automatic FWD
- 2.0L Ford EcoBlue 170 PS (125 kW) Automatic AWD



Unique Molten Grey deco spear insert

Adaptive Cruise Control

Electric parking brake

3 CUSTOMISE

Tourneo Custom allows you to get creative with a choice of stylish, classic and bold colours.



Grey Matter
Premium body colour*

COLOURS



Blazer Blue
Solid body colour



Agate Black
Metallic body colour*



Magnetic
Metallic body colour*



Frozen White
Solid body colour



Artisan Red†
Metallic body colour*



Moondust Silver
Metallic body colour*



Race Red
Solid body colour



Chrome Blue
Metallic body colour*

Note The images used are to illustrate body colours only and may not reflect the vehicle described. Colours and trims reproduced within this brochure may vary from the actual colours, due to the limitations of the printing processes used.

*Metallic and premium body colours are options, at extra cost.

†Not available on Zetec series.

3 CUSTOMISE

TOUGHNESS IN EVERY DETAIL

A multi-stage paint process helps ensure your Tourneo looks its best for years to come.

From wax-injected steel body sections to the hard-wearing top coat, toughness has been built into every layer. And a 12-year perforation warranty offers you further peace of mind.



1
Zinc coating

2
Phosphate coat

3
Electrocoat

4
Primer

5
Top coat

6
Clearcoat*

*Not with Frozen White body colour.

3 CUSTOMISE

TRIMS



Plus in Black Onyx/City in Black Onyx
Standard on Zetec



Barlo Pin Hex Emboss in Black Onyx/Barlo in Black Onyx
Standard on Titanium



Barlo Pin Hex Emboss in Medium Urban Grey/Barlo in Medium Urban Grey
Optional on Titanium





16"
Sparkle Silver alloy wheel
Standard on Zetec



17"
Twin-spoke alloy wheel in Carbonised Grey
Standard on Titanium, optional on Zetec



19"
Multi-spoke alloy wheel in Luster Nickel
Optional on Titanium

3 CUSTOMISE

OPTION AND ACCESSORY



1



2



3



4



5

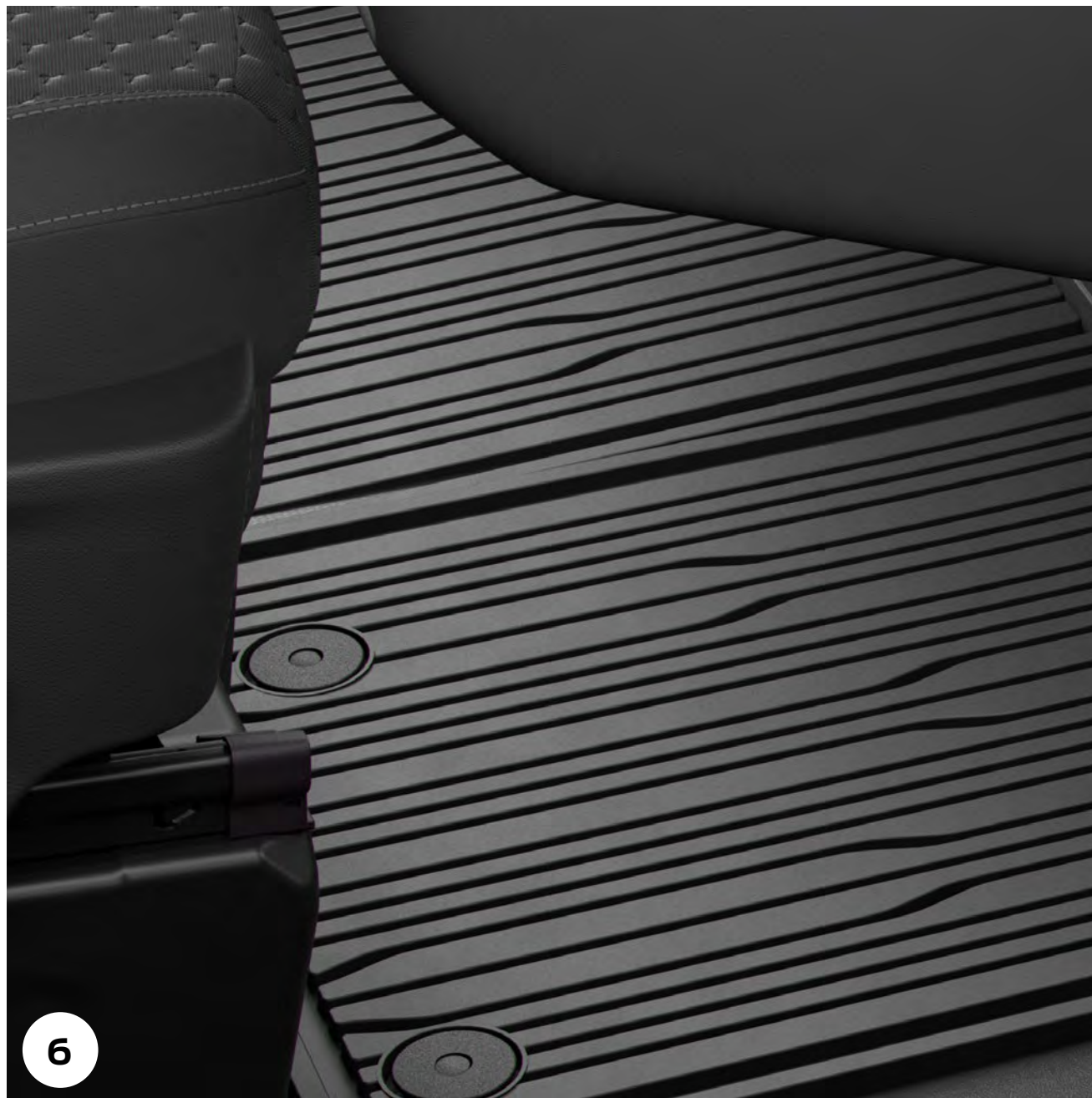

6

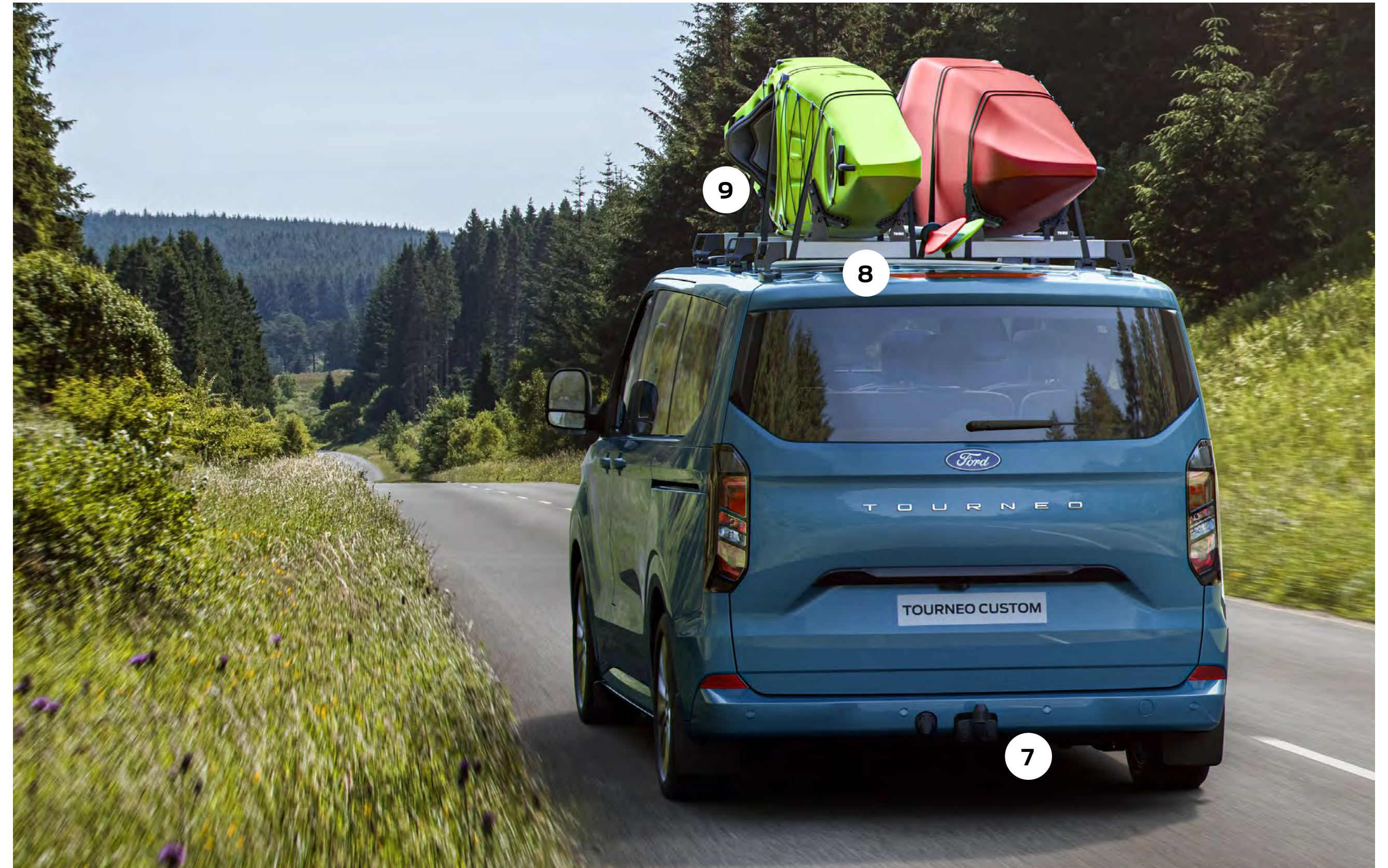

9

8

7

- 1 Carpet floor mats**
- 2 Smart mirror
- 3 Tablet holder
- 4 Dashboard camera
- 5 Coat hanger
- 6 All-weather floor mats
- 7 Fixed tow bar**

- 8 Integrated and foldable roof rack**
- 9 Thule®+ roof kayak carrier DockGrip

+Item covered by third party supplier's warranty, please see back cover for details.

**Option and Accessory.

Items ordered as an option will be fitted in the factory. If ordered as an accessory, items will be fitted at the Dealership. Fitment of accessories may have an impact on your vehicle's fuel consumption.

For more accessories visit www.ford-accessories.com

For a range of Ford branded merchandise – from clothing to lifestyle and travel products – visit www.fordlifestylecollection.com

3 CUSTOMISE

FIXED AND DETACHABLE TOW BAR

Engineered specifically for your vehicle and designed for full compatibility and integration with its electrical system, the Ford range of tow bars offers a variety of robust solutions for business and leisure needs. (Option and/or accessory)



INTEGRATED AND FOLDABLE ROOF RACK

Transport a range of loads easily. Sturdy, lightweight, aerodynamic, folds flat when not required and compatible with Thule®+ roof attachments. (Option and accessory)

- 155 kg max. capacity when three racks are folded up
- 75 kg max. capacity when two racks are folded up

+Item covered by third party supplier's warranty, please see back cover for details.



ACCESSORIES

LOAD COMPARTMENT MAT

Help keep your vehicle nice and clean. This mat has been designed to fit your vehicle perfectly, with raised edges that help protect the third row from dust and dirt. Can easily be removed for cleaning. (Option and accessory)

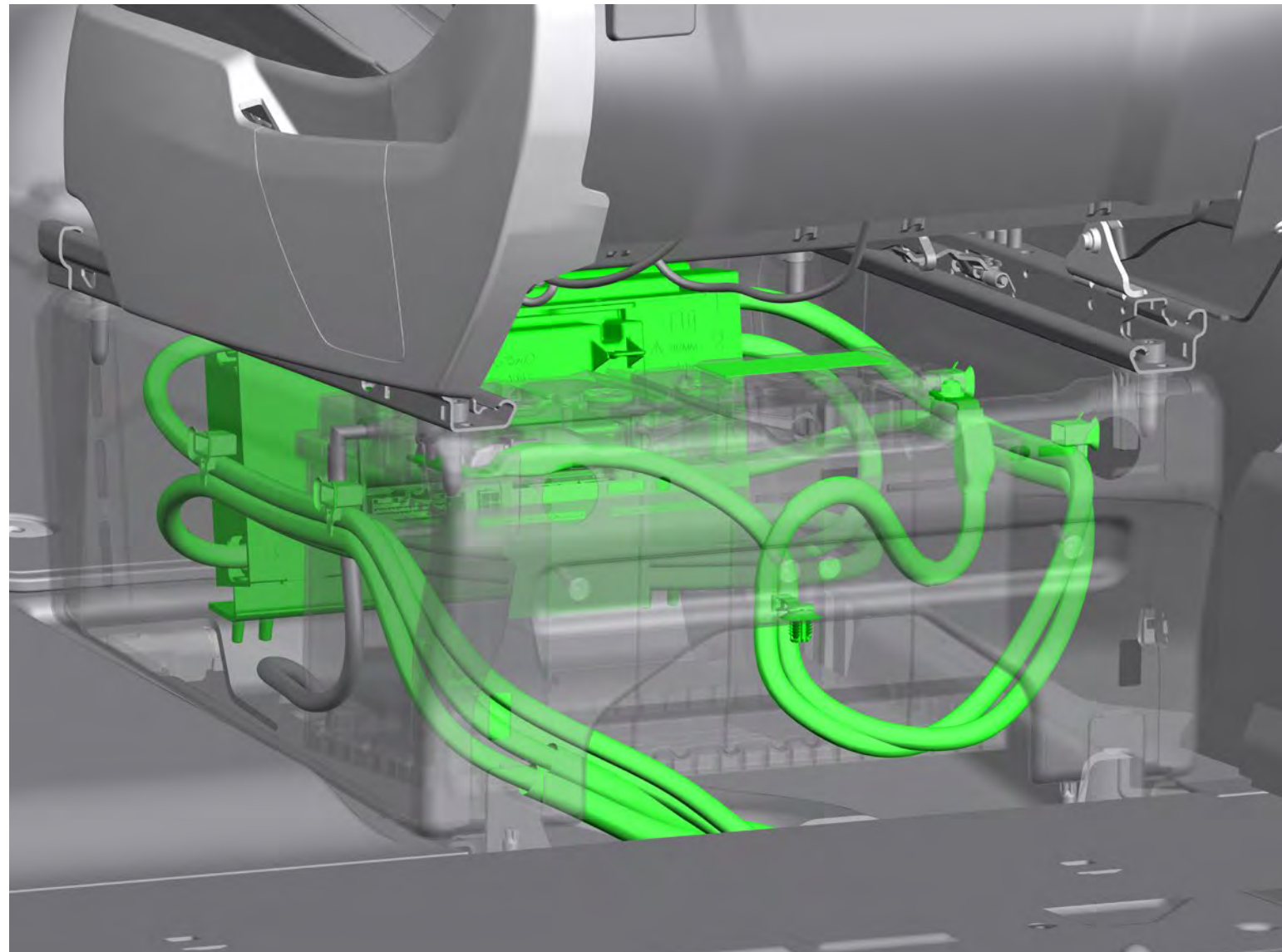

SMART FUSE BOX

The all-new design combines several features into one multi-purpose unit. Featuring a high-current fuse box, Ford Programmable Battery Guard, selected vehicle signals, and offering the ability to support split charging capability. The fuse box is also configurable with 8 inputs and 8 outputs and offers up to 250A of power management capability.



ENGINE RPM CONTROL*†

This allows the engine to be run at an elevated idle speed, providing an electrical and mechanical power take-off to drive supplementary equipment – ideal for refrigeration and utility conversions. (Requires a third-party control box)

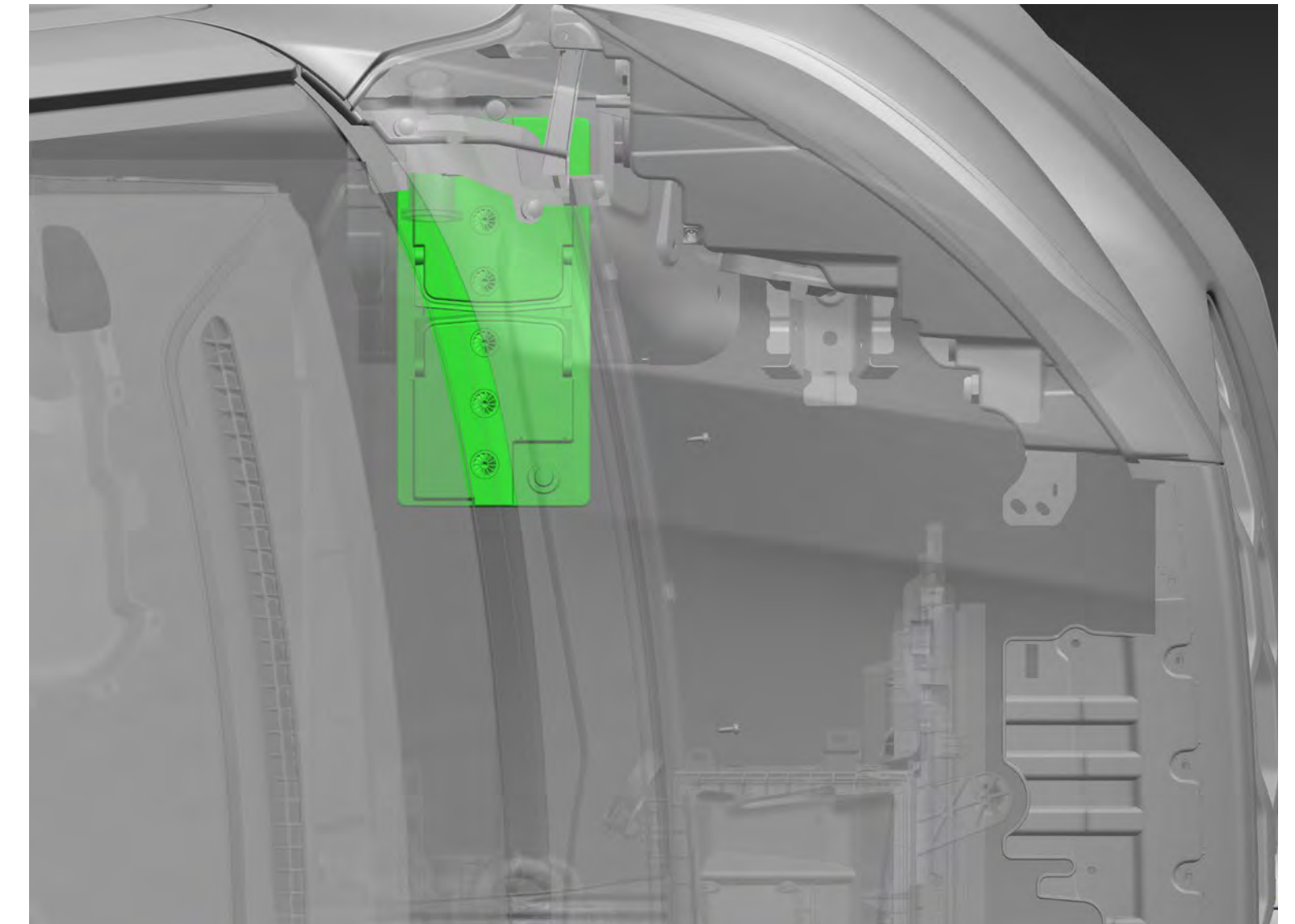

SINGLE H8 AGM BATTERY*†

Suitable for vehicles requiring engine-off power requirements higher than a standard battery – this 95 Ah H8 AGM deep cycle battery is more resistant to a cycle of heavy charge and discharge, and resists fading over time.

- Ideal for conversions requiring telematics or trackers



FIRST AND SECOND ROW SEATING

This option offers the vehicle without the third row of seats and their restraints. The floor covering is retained, creating an ideal platform for a wheelchair access conversion or creating an exceptional loadspace for luggage, tools or sports equipment.

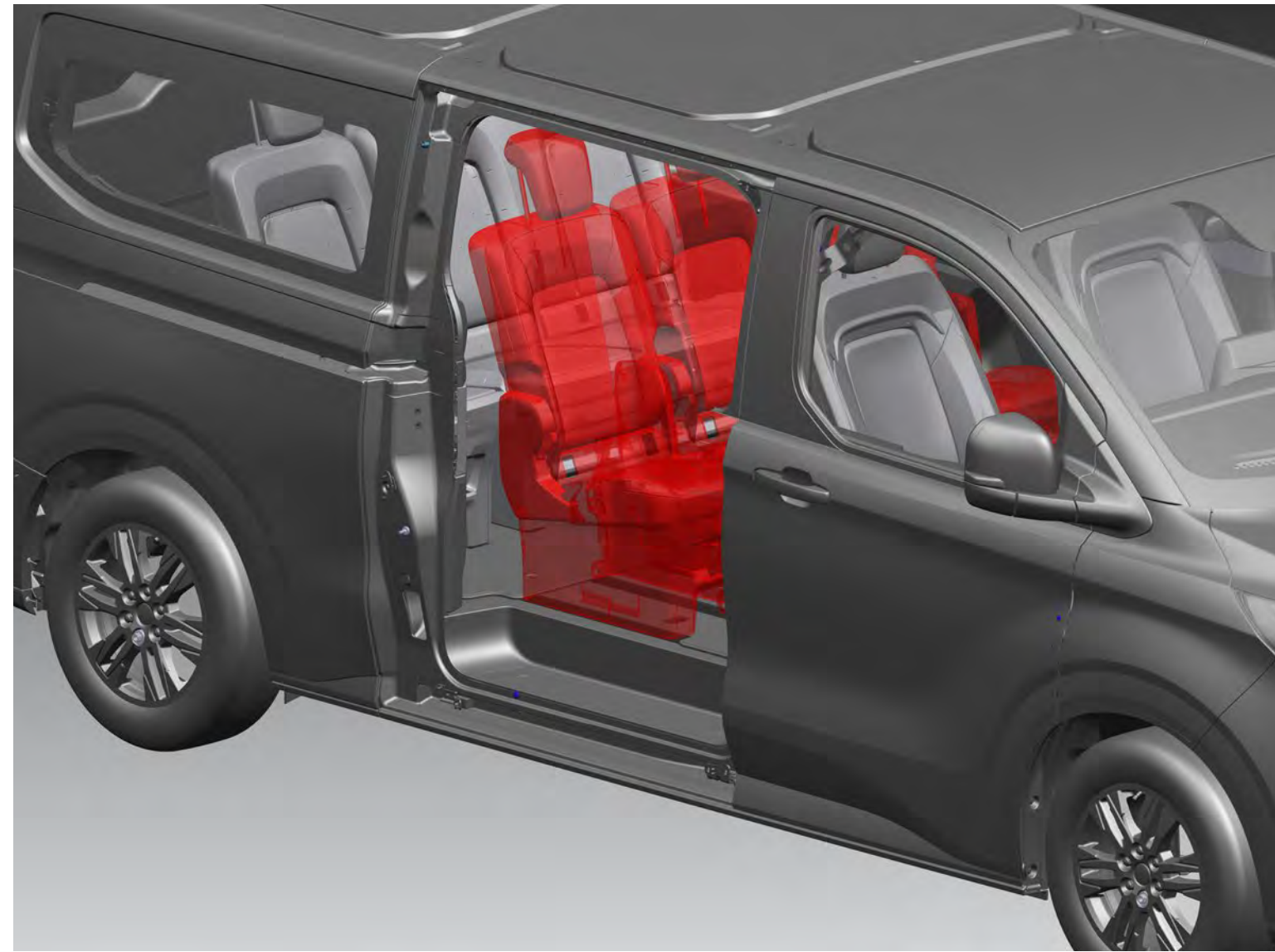

TAXI PACK

The optional Taxi Pack provides the vehicle ready for conversion with the second row of seating and their restraints removed. Making it ideal for wheelchair access modification or where the standard second row seats are not required – for example, replacing them with second row flip-seating.

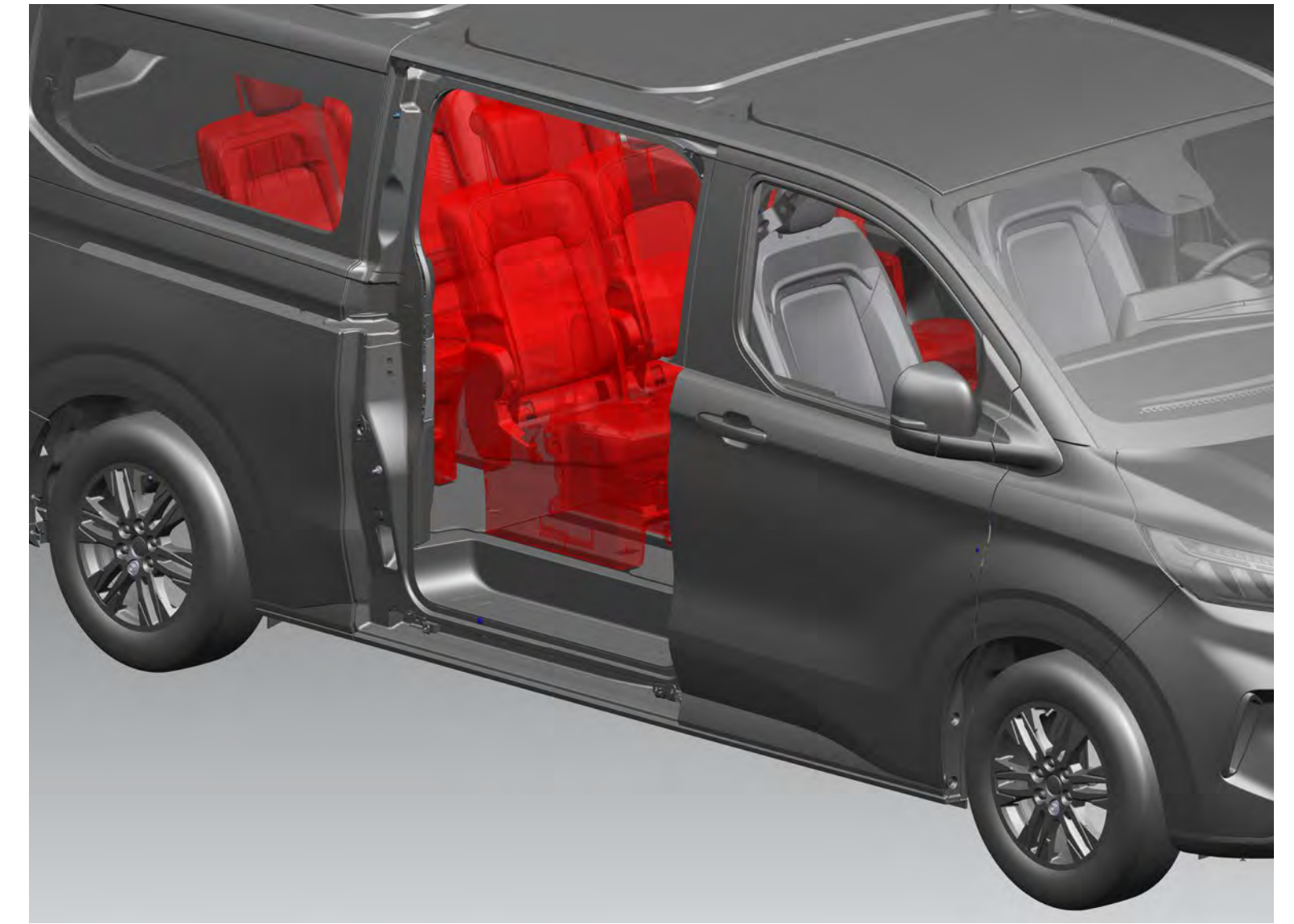

TAXI PREP PACK ENGINEER

The Tourneo Custom can be provided with the second and third row of seating, and their restraints removed, as well as the floor coverings. This option creates the optimum space for a wheelchair conversion or any other use where maximum loadspace is the foundation for modification.

4

SPECIFICATIONS

Discover the right solution for your needs.

FUEL ECONOMY AND CO₂ EMISSIONS

EU 6.2	Axle ratio ^o	CO ₂ emissions (g/km) ^{oo}	Fuel consumption in L/100 km ^{oo} Combined
TOURNEO CUSTOM (L1)			
2.0L TDCi Ford EcoBlue 136 PS (100 kW)	4.93	193-201	7.4-7.7
2.0L TDCi Ford EcoBlue 136 PS (100 kW) 8-speed automatic FWD	3.65	209-217	8.0-8.3
2.0L TDCi Ford EcoBlue 136 PS (100 kW) 8-speed automatic AWD	3.65	226-233	8.6-8.9
2.0L TDCi Ford EcoBlue 150 PS (110 kW)	4.93	193-201	7.4-7.7
2.0L TDCi Ford EcoBlue 170 PS (125 kW) 8-speed automatic FWD	3.65	210-217	8.1-8.3
2.0L TDCi Ford EcoBlue 170 PS (125 kW) 8-speed automatic AWD	3.65	226-233	8.6-8.9
TOURNEO CUSTOM (L2)			
2.0L TDCi Ford EcoBlue 136 PS (100 kW)	4.93	193-203	7.4-7.7
2.0L TDCi Ford EcoBlue 136 PS (100 kW) 8-speed automatic FWD	3.65	209-219	8.1-8.4
2.0L TDCi Ford EcoBlue 136 PS (100 kW) 8-speed automatic AWD	3.65	226-234	8.6-8.9
2.0L TDCi Ford EcoBlue 150 PS (110 kW)	4.93	194-203	7.4-7.7
2.0L TDCi Ford EcoBlue 170 PS (125 kW) 8-speed automatic FWD	3.65	210-219	8.0-8.4
2.0L TDCi Ford EcoBlue 170 PS (125 kW) 8-speed automatic AWD	3.65	226-234	8.6-8.9

^oThe illustrated axle ratio shown is the one available dependent upon model, GVM payload and engine/transmission combination.

^{oo}The declared fuel/energy consumptions, CO₂ emissions and electric ranges are determined according to the technical requirements and specifications of the European Regulations (EC) 715/2007 and (EU) 2017/1151 as last amended. Light Duty vehicles type-approved using the Worldwide Harmonised Light Vehicle Test Procedure (WLTP) will have fuel/energy consumptions and CO₂ emission information for New European Drive Cycle (NEDC) and WLTP. WLTP will fully replace the NEDC latest by end of the year 2020. The applied standard test procedures enable comparison between different vehicle types and different manufacturers. In addition to the fuel efficiency of a vehicle, driving behaviour as well as other non-technical factors play a role in determining a vehicle's fuel/energy consumption, CO₂ emissions and electric ranges. CO₂ is the main greenhouse gas responsible for global warming. A guide on fuel economy and CO₂ emissions which contains data for all new passenger carrying vehicle models is available at any point of sale free of charge or can be downloaded under <https://carfueldata.vehicle-certification-agency.gov.uk/>

WEIGHTS AND LOADS

	Max. gross payload (excluding driver/passenger) (kg) ^{oo}	Gross vehicle mass (kg)	Min. kerb mass (excluding driver/passenger) (kg) *	Front axle plated mass (kg)	Rear axle plated mass (kg)	Axle ratio ^o	Max. GTM (kg)	Max. trailer mass range (kg) ^(a)	
								Braked	Unbraked
TOURNEO CUSTOM L1 (M1)									
2.0L TDCi Ford EcoBlue 136 PS (100 kW)	966-1049	3225	2176-2259	1650	1725	4.93	5725	2500	750
2.0L TDCi Ford EcoBlue 136 PS (100 kW) 8-speed automatic FWD	928-1006	3225	2214-2297	1650	1700	3.65	5725	2500	750
2.0L TDCi Ford EcoBlue 136 PS (100 kW) 8-speed automatic AWD	904-982	3300	2313-2396	1700	1725	3.65	5700	2400	750
2.0L TDCi Ford EcoBlue 150 PS (110 kW)	966-1024	3225	2201-2259	1650	1725	4.93	5725	2500	750
2.0L TDCi Ford EcoBlue 170 PS (125 kW) 8-speed automatic FWD	928-986	3225	2239-2297	1650	1700	3.65	5725	2500	750
2.0L TDCi Ford EcoBlue 170 PS (125 kW) 8-speed automatic AWD	904-962	3300	2338-2396	1700	1725	3.65	5700	2400	750
TOURNEO CUSTOM L2 (M1)									
2.0L TDCi Ford EcoBlue 136 PS (100 kW)	920-1003	3225	2222-2305	1750	1675	4.93	5725	2500	750
2.0L TDCi Ford EcoBlue 136 PS (100 kW) 8-speed automatic FWD	882-965	3225	2260-2343	1750	1675	3.65	5725	2500	750
2.0L TDCi Ford EcoBlue 136 PS (100 kW) 8-speed automatic AWD	858-941	3300	2359-2442	1750	1700	3.65	5700	2400	750
2.0L TDCi Ford EcoBlue 150 PS (110 kW)	920-978	3225	2247-2305	1750	1675	4.93	5725	2500	750
2.0L TDCi Ford EcoBlue 170 PS (125 kW) 8-speed automatic FWD	882-940	3225	2285-2343	1750	1675	3.65	5725	2500	750
2.0L TDCi Ford EcoBlue 170 PS (125 kW) 8-speed automatic AWD	858-916	3300	2385-2442	1750	1700	3.65	5700	2400	750

L1 = Short wheelbase, L2 = Long wheelbase. ^oThe illustrated axle ratio shown is one available dependent upon model, GVM and engine combination. ^{oo}Gross payload = Gross vehicle mass, less kerb mass. **GVM** = Gross vehicle mass. The total permissible all-up weight of a rigid vehicle – i.e. with body, payload, ancillaries, fuel, oil, water, driver and crew. *Kerb mass is affected by many factors such as bodystyles, engines and options (different series will have different kerb masses), including 100% full fluids, 90% full fuel tank and without the driver (75 kg), crew or cargo. Payload within this guide is the difference between gross vehicle mass (GVM) and kerb mass. It must be noted that actual weight will always be subject to manufacturing tolerances which may result in payload variations between this guide and actual weight. **NB:** It is the responsibility of the vehicle operator to ensure their vehicles are legally compliant for road use. ^(a)Max. braked trailer mass is dependent on chosen engine power and dependent on the additional options/equipment selected. **GTM** = Gross train mass. The total permissible all-up weight of a rigid vehicle (see GVM) together with its trailer and load.

4 SPECIFICATIONS

DIMENSIONS (MM)

	9-seat Tourneo Custom	
	L1	L2
Overall length	5050	5450
Overall width (with fold-back mirrors)	2275 (2148)	2275 (2148)
Overall height*	1963-1983	1961-1981
Side door entry width	936	936
Luggage space between wheel arches	1392	1392
Luggage space width	1777	1777
Luggage space floor to roof	1415	1415
Luggage space length (at base of third row seats)	515-725	915-1125
LUGGAGE CAPACITY (LITRES)		
Luggage capacity (behind third row of seats up to roof)	673-1045	819-1345
TURNING CIRCLE (M)		
16" wheels, kerb to kerb/wall to wall	10.9 m/11.6 m	12.1 m/12.8 m
17" wheels, kerb to kerb/wall to wall	10.9 m/11.6 m	12.1 m/12.8 m
19" wheels, kerb to kerb/wall to wall	11.6 m/12.3 m	12.9 m/13.6 m

L1 = Short wheelbase, L2 = Long wheelbase. All dimensions (shown in mm) are subject to manufacturing tolerances and refer to minimum specification models and do not include additional equipment. These illustrations are for guidance only. *Height dimensions show the range from minimum to maximum of a fully laden, lowest payload vehicle to unladen highest payload vehicle.

DIMENSIONS

L1 H1

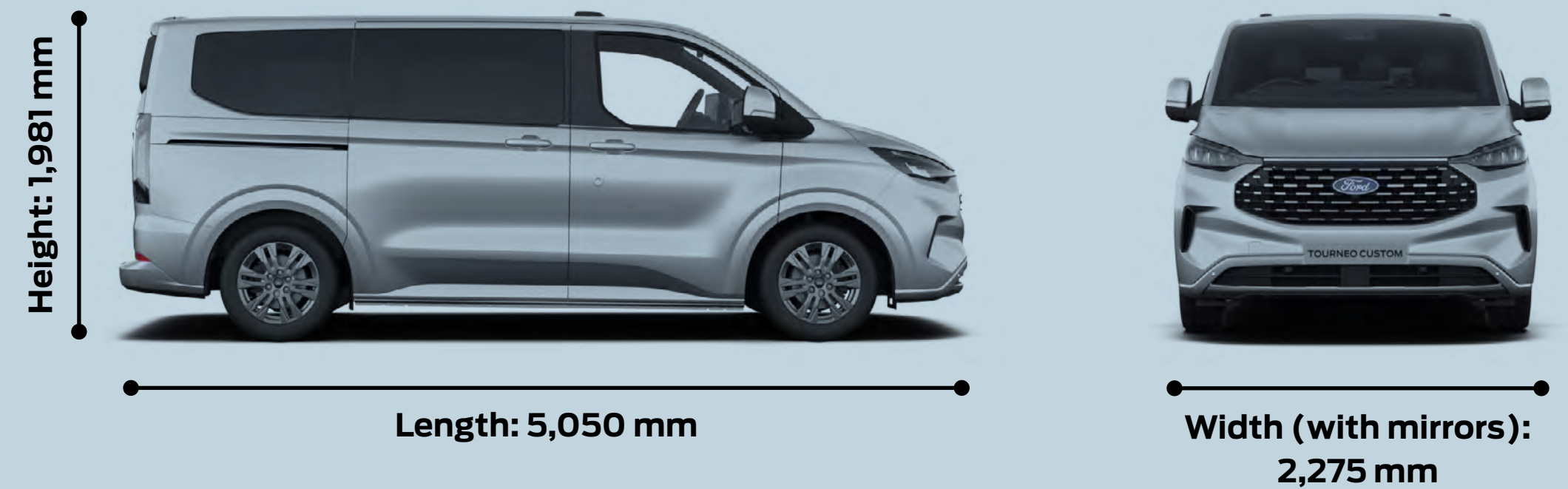

L2 H1

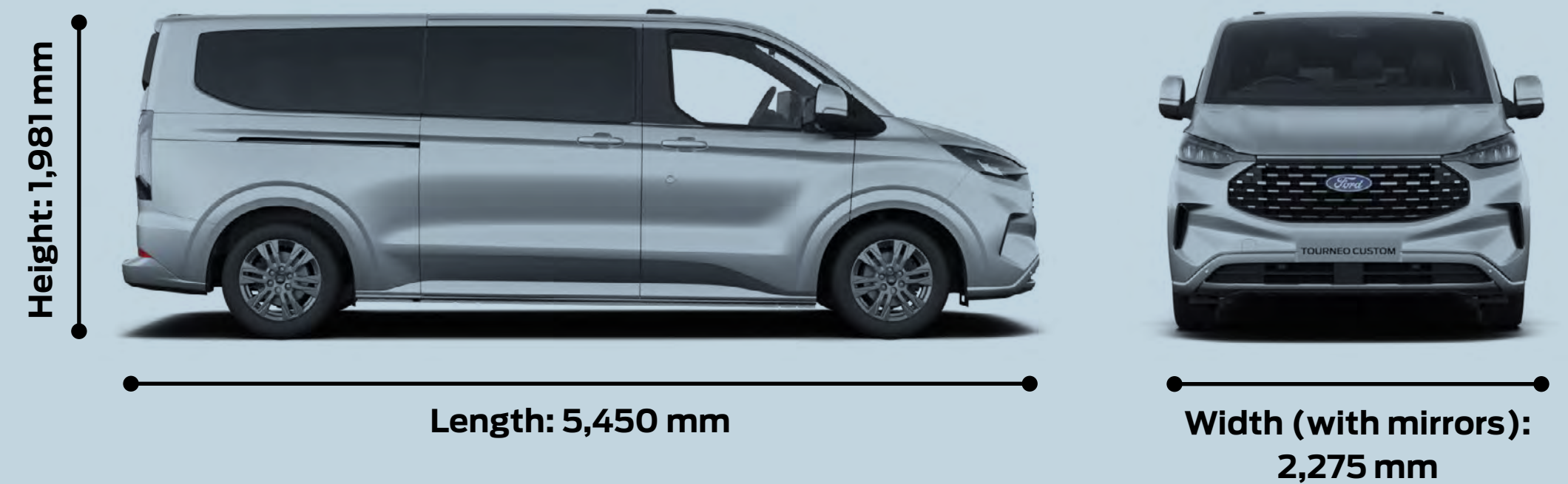

4 SPECIFICATIONS

MODEL AVAILABILITY

	320 L1	320 L2
TOURNEO CUSTOM BUS		
2.0L TDCi Ford EcoBlue 136 PS (100 kW)	<input checked="" type="checkbox"/>	<input checked="" type="checkbox"/>
2.0L TDCi Ford EcoBlue 136 PS (100 kW) 8-speed automatic	<input checked="" type="checkbox"/>	<input checked="" type="checkbox"/>
2.0L TDCi Ford EcoBlue 150 PS (110 kW)	<input checked="" type="checkbox"/>	<input checked="" type="checkbox"/>
2.0L TDCi Ford EcoBlue 170 PS (125 kW) 8-speed automatic	<input checked="" type="checkbox"/>	<input checked="" type="checkbox"/>

All engines are EU 6.2 with manual transmission unless otherwise stated. L1 = Short wheelbase, L2 = Long wheelbase.

Available

STYLING AND APPEARANCE

	Zetec	Titanium
WHEELS		
16" alloy wheel in Sparkle Silver (fitted with 215/65 R16 BSW tyres)*	<input checked="" type="checkbox"/>	—
17" twin-spoke alloy wheel in Carbonised Grey (fitted with 215/60 R17 BSW tyres)*	<input type="checkbox"/>	<input checked="" type="checkbox"/>
19" multi-spoke alloy wheel in Lustre Nickel (fitted with 235/50 R19 tyres)*	—	<input type="checkbox"/>
Spare – 16" steel (requires AWD)	<input checked="" type="checkbox"/>	<input checked="" type="checkbox"/>
Spare – Temporary (requires FWD)	<input checked="" type="checkbox"/>	<input checked="" type="checkbox"/>
Locking wheel nuts	<input type="checkbox"/>	<input checked="" type="checkbox"/>
DESIGN FEATURES		
Front bumper – Body colour	—	<input checked="" type="checkbox"/>
Front bumper – Partial body colour	<input checked="" type="checkbox"/>	—
Rear bumper – Body colour	—	<input checked="" type="checkbox"/>
Rear bumper – Partial body colour	<input checked="" type="checkbox"/>	—
Door handles – Body colour	<input checked="" type="checkbox"/>	<input checked="" type="checkbox"/>
Tailgate handle – Body colour	<input checked="" type="checkbox"/>	<input checked="" type="checkbox"/>
Tinted glass – Complete	<input checked="" type="checkbox"/>	<input type="checkbox"/>
Rear privacy glass	<input type="checkbox"/>	<input checked="" type="checkbox"/>
Rear window – Heated	<input checked="" type="checkbox"/>	<input checked="" type="checkbox"/>
Mudflaps – Front	<input type="checkbox"/>	<input type="checkbox"/>
Mudflaps – Rear	<input type="checkbox"/>	<input type="checkbox"/>
Complete underbody corrosion protection	<input type="checkbox"/>	<input type="checkbox"/>
Panorama roof	<input type="checkbox"/>	<input type="checkbox"/>
PAINT		
Paint – Solid	<input checked="" type="checkbox"/>	<input checked="" type="checkbox"/>
Paint – Metallic	<input type="checkbox"/>	<input type="checkbox"/>

*The wheel you choose will be fitted with the tyre size noted, but no choice of tyre brand is available.

Standard Option, at extra cost Part of an option pack at extra cost.

4 SPECIFICATIONS

DRIVING EXPERIENCE

	Zetec	Titanium
DRIVER ASSISTANCE		
Speed Limiter – 100 km/h (62 mph)	<input type="checkbox"/>	<input type="checkbox"/>
Speed Limiter – 110 km/h (70 mph)	<input type="checkbox"/>	<input type="checkbox"/>
Speed Limiter – 130 km/h (80 mph)	<input type="checkbox"/>	<input type="checkbox"/>
Lane Change Warning and Aid ²⁾ (requires manual transmission)	<input checked="" type="checkbox"/>	<input checked="" type="checkbox"/>
Adaptive Cruise Control ²⁾ (requires manual transmission)	<input checked="" type="checkbox"/>	<input checked="" type="checkbox"/>
Adaptive Cruise Control ²⁾ with Stop & Go (requires automatic transmission)	<input checked="" type="checkbox"/>	<input checked="" type="checkbox"/>
Blind Spot Information System with Trailer Coverage and Cross Traffic Alert ²⁾	<input checked="" type="checkbox"/>	<input checked="" type="checkbox"/>
Intelligent Speed Assist	<input checked="" type="checkbox"/>	<input checked="" type="checkbox"/>
Speed Sign Recognition 3	<input checked="" type="checkbox"/>	<input checked="" type="checkbox"/>
Parking distance sensors – Front and rear	<input checked="" type="checkbox"/>	<input checked="" type="checkbox"/>
Wrong Way Alert	<input checked="" type="checkbox"/>	<input checked="" type="checkbox"/>
Fixed rear-view camera	<input checked="" type="checkbox"/>	<input checked="" type="checkbox"/>
EXTERIOR LIGHTING		
Headlights – Fixed LED DSS headlights with daytime running lights	<input checked="" type="checkbox"/>	<input checked="" type="checkbox"/>
Headlights – Automatic on/off	<input checked="" type="checkbox"/>	<input checked="" type="checkbox"/>
INSTRUMENTS AND CONTROLS		
Tyre Pressure Monitoring System (TPMS) ¹⁾	<input checked="" type="checkbox"/>	<input checked="" type="checkbox"/>
OPTION PACKS		
DAP 5 Driver Assistance Pack with Navigation (in additional to DAP 2 Parking Pack): – Anti-Locking Brake System with Electric Stability Control and Electric Brake Boost – Sensico®-trimmed steering wheel – Adaptive Cruise Control (requires manual transmission) – Adaptive Cruise Control with Stop & Go (requires automatic transmission) – Navigation Centre – Blind Spot Information System with Cross Traffic Alert and Trailer Lite – Lane Change Warning and Aid – Front parking distance sensors – Reverse Brake Assist – Fixed rear-view camera	<input checked="" type="checkbox"/>	<input checked="" type="checkbox"/>

¹⁾Safety feature, ²⁾Driver Assistance feature.

PERFORMANCE AND EFFICIENCY

	Zetec	Titanium
ENGINE		
2.0L TDCi Ford EcoBlue 136 PS (100 kW)	<input type="checkbox"/>	<input type="checkbox"/>
2.0L TDCi Ford EcoBlue 136 PS (100 kW) 8-speed automatic	<input type="checkbox"/>	<input type="checkbox"/>
2.0L TDCi Ford EcoBlue 150 PS (110 kW)	–	<input type="checkbox"/>
2.0L TDCi Ford EcoBlue 170 PS (125 kW) 8-speed automatic	–	<input type="checkbox"/>
INSTRUMENTS AND CONTROLS		
Trip computer – Distance to empty, instant and average fuel consumption, average speed, outside temperature	<input checked="" type="checkbox"/>	<input checked="" type="checkbox"/>
Water in fuel filter with sensor	<input checked="" type="checkbox"/>	<input checked="" type="checkbox"/>
Battery – Single H7 AGM	<input checked="" type="checkbox"/>	<input checked="" type="checkbox"/>
Battery – Dual H7 AGM heavy-duty	<input type="checkbox"/>	<input type="checkbox"/>
Battery – Dual H8 AGM extra heavy-duty	<input type="checkbox"/>	<input type="checkbox"/>
Battery – Single H8 AGM	<input type="checkbox"/>	<input type="checkbox"/>
Alternator – Eco innovation (TBC Amp)	<input checked="" type="checkbox"/>	<input checked="" type="checkbox"/>
TECHNOLOGY		
Smart acceleration control	<input type="checkbox"/>	<input type="checkbox"/>
Standard fuel tank – 55 litres	<input checked="" type="checkbox"/>	<input checked="" type="checkbox"/>
Extended range single fuel tank – 70 litres	<input type="checkbox"/>	<input type="checkbox"/>
Urea after treatment system – 21 litre	<input checked="" type="checkbox"/>	<input checked="" type="checkbox"/>
Electric power-assisted steering (EPAS)	<input checked="" type="checkbox"/>	<input checked="" type="checkbox"/>

All engines are EU 6.2 with manual transmission unless otherwise stated.

Standard Option, at extra cost Part of an option pack at extra cost.

4 SPECIFICATIONS

COMFORT AND CONVENIENCE

	Zetec	Titanium
INTERIOR CONVENIENCE		
Small overhead console	<input checked="" type="checkbox"/>	<input checked="" type="checkbox"/>
Bottle holder – Twin, 2-litre bottle capacity, facia-mounted	<input checked="" type="checkbox"/>	<input checked="" type="checkbox"/>
Glovebox – Lockable	<input checked="" type="checkbox"/>	<input checked="" type="checkbox"/>
Large console	<input type="checkbox"/>	<input type="checkbox"/>
Small console	<input checked="" type="checkbox"/>	<input checked="" type="checkbox"/>
Storage – Front door map pockets	<input checked="" type="checkbox"/>	<input checked="" type="checkbox"/>
Storage – Storage compartment on facia top with lift-up lid	<input checked="" type="checkbox"/>	<input checked="" type="checkbox"/>
Sunblinds – Second and third row (second row only on L1)	<input checked="" type="checkbox"/>	<input checked="" type="checkbox"/>
Day/night rear-view mirror	<input checked="" type="checkbox"/>	<input checked="" type="checkbox"/>
AUDIO AND COMMUNICATION SYSTEMS		
ICE Pack 3 – Ford SYNC 4 with 5G embedded modem, 13" touchscreen display with Navigation Centre and 10 radio speakers	<input checked="" type="checkbox"/>	<input checked="" type="checkbox"/>
CLIMATE CONTROL		
Air conditioning – Front, automatic temperature control	<input checked="" type="checkbox"/>	<input checked="" type="checkbox"/>
Air conditioning – Front, Dual-zone Automatic Temperature Control	<input type="checkbox"/>	<input type="checkbox"/>
Air conditioning – Front and rear, Tri-zone Automatic Temperature Control (includes rear seat electric climate control)	<input type="checkbox"/>	<input type="checkbox"/>
Air conditioning – Rear, includes front air conditioning	<input type="checkbox"/>	<input checked="" type="checkbox"/>
Air conditioning – Rear electric, includes front air conditioning	<input checked="" type="checkbox"/>	<input checked="" type="checkbox"/>
Heater – Recirculation	<input checked="" type="checkbox"/>	<input checked="" type="checkbox"/>
INTERIOR LIGHTING		
Courtesy lights – Header-mounted, front	<input checked="" type="checkbox"/>	<input checked="" type="checkbox"/>
Courtesy lights – Rear seat courtesy lights with reading lights	<input checked="" type="checkbox"/>	<input checked="" type="checkbox"/>
Loadspace compartment lights	<input checked="" type="checkbox"/>	<input checked="" type="checkbox"/>
Loadspace compartment picnic lights (only available with tailgate)	<input type="checkbox"/>	<input type="checkbox"/>

COMFORT AND CONVENIENCE

	Zetec	Titanium
SEATING		
Seat Pack 32 Entry+ – 4-way manual individual driver's seat adjust (fore/aft and recline) with lumbar support and 2-way manual individual passenger's seat adjust (fore/aft) with passenger airbag and side/curtain airbags	<input checked="" type="checkbox"/>	<input type="checkbox"/>
Seat Pack 11A Entry+ – 4-way manual individual driver's seat adjust (fore/aft and recline) with lumbar support with dual passenger seat, tray table, passenger airbags and side/curtain airbags	<input type="checkbox"/>	<input type="checkbox"/>
Seat Pack 16A Comfort – 4-way manual individual heated driver's seat adjust (fore/aft and recline) with lumbar support and adjustable armrests and dual heated passenger seat with tray table, passenger airbags and side/curtain airbags	<input type="checkbox"/>	<input type="checkbox"/>
Seat Pack 7 Complete – 4-way manual individual heated driver's seat adjust (fore/aft and recline) with lumbar support and adjustable armrests and 2-way manual individual heated passenger's seat adjust (fore/aft) with inboard armrests and passenger airbag and side/curtain airbags	<input type="checkbox"/>	<input type="checkbox"/>
Seat Pack 17A AGR – 6-way manual individual heated driver's seat adjust (fore/aft, recline and height) with 4-way lumbar support and adjustable armrests with heated dual passenger seat, tray table, passenger airbag and side/curtain airbags	<input type="checkbox"/>	<input type="checkbox"/>
Seat Pack 16 Complete Dark – 4-way manual individual heated driver's seat adjust (fore/aft and recline) with lumbar support and adjustable armrests and 4-way manual individual heated passenger's seat adjust (fore/aft and recline) with lumbar support and inboard armrests and passenger airbag and side/curtain airbags	<input type="checkbox"/>	<input checked="" type="checkbox"/>
Seat Pack 49 Complete Dark – 4-way manual individual heated driver's seat adjust (fore/aft and recline) with lumbar support and adjustable armrests and dual heated passenger seat with tray table and passenger airbag and side/curtain airbags	<input type="checkbox"/>	<input type="checkbox"/>
Seat Pack 9 Complete Light – 4-way manual individual heated driver's seat adjust (fore/aft and recline) with lumbar support and adjustable armrests and 4-way manual individual heated passenger's seat adjust (fore/aft and recline) with lumbar support and inboard armrests and passenger airbag and side/curtain airbags	<input type="checkbox"/>	<input type="checkbox"/>
Seat Pack 18A Complete Light – 4-way manual individual heated driver's seat adjust (fore/aft and recline) with lumbar support and adjustable armrests and dual heated passenger seat with tray table and passenger airbag and side/curtain airbags	<input type="checkbox"/>	<input type="checkbox"/>
Seat Pack 4 AGR Dark – 6-way manual individual heated driver's and passenger's seat adjust (fore/aft, recline and height) with 4-way lumbar support and adjustable armrests and passenger airbag and side/curtain airbags	<input type="checkbox"/>	<input type="checkbox"/>
Seat Pack 11 AGR Light – 6-way manual individual heated driver's and passenger's seat adjust (fore/aft, recline and height) with 4-way lumbar support and adjustable armrests and passenger airbag and side/curtain airbags	<input type="checkbox"/>	<input type="checkbox"/>
Rear Seat Pack 14 – Contains dual side load doors, second row individual seats with fore/aft adjust and stowage and third row single/double seats with stowage	<input checked="" type="checkbox"/>	<input checked="" type="checkbox"/>

Note: The Bluetooth® Wordmark and logos are owned by the Bluetooth SIG, Inc. and any use of such marks by Ford Motor Company Limited is under licence. Other trademarks and trade names are those of their respective owners.

Standard Option, at extra cost Part of an option pack at extra cost.

4 SPECIFICATIONS

COMFORT AND CONVENIENCE

	Zetec	Titanium
INSTRUMENTS AND CONTROLS		
Steering column – Fixed	<input checked="" type="checkbox"/>	<input checked="" type="checkbox"/>
Door mirrors – Automatic power-foldable, electrically-operated and heated	<input checked="" type="checkbox"/>	<input checked="" type="checkbox"/>
Door mirrors – Body colour caps	<input checked="" type="checkbox"/>	<input checked="" type="checkbox"/>
Wipers – Automatic with rain sensor	<input checked="" type="checkbox"/>	<input checked="" type="checkbox"/>
Wipers – Rear with auto-reverse wipe and electrically-operated wash	<input checked="" type="checkbox"/>	<input checked="" type="checkbox"/>
Grab Handles – Includes driver’s sunglasses holder and grab handles	<input checked="" type="checkbox"/>	<input checked="" type="checkbox"/>
Steering wheel – Sensico®-trimmed	<input checked="" type="checkbox"/>	<input checked="" type="checkbox"/>
Steering wheel – Heated	<input type="checkbox"/>	<input type="checkbox"/>
Gearshift knob – Sensico®-trimmed (requires manual transmission)	<input checked="" type="checkbox"/>	<input checked="" type="checkbox"/>
Sun visor – Driver and passenger, illuminated	<input checked="" type="checkbox"/>	<input checked="" type="checkbox"/>
Windows – Electrically-operated front with one-touch-lowering on driver and passenger’s side	<input checked="" type="checkbox"/>	<input checked="" type="checkbox"/>
Ford Keyfree System with Ford Power starter button (fully keyless vehicle)	<input checked="" type="checkbox"/>	<input checked="" type="checkbox"/>
TECHNOLOGY		
Ford Easy Fuel capless refuelling system with misfuel inhibit	<input checked="" type="checkbox"/>	<input checked="" type="checkbox"/>
Windscreen – Quickclear heated	<input checked="" type="checkbox"/>	<input checked="" type="checkbox"/>
Windscreen – Rear defroster	<input checked="" type="checkbox"/>	<input checked="" type="checkbox"/>
Wireless charging	<input type="checkbox"/>	<input type="checkbox"/>

Note: The Bluetooth® Wordmark and logos are owned by the Bluetooth SIG, Inc. and any use of such marks by Ford Motor Company Limited is under licence. Other trademarks and trade names are those of their respective owners.

SAFETY AND SECURITY

	Zetec	Titanium
SAFETY		
Anti-lock braking system (ABS) with electronic brake-force distribution (EBD) ¹⁾	<input checked="" type="checkbox"/>	<input checked="" type="checkbox"/>
Airbag – Driver’s ¹⁾	<input checked="" type="checkbox"/>	<input checked="" type="checkbox"/>
Airbag – Front passenger’s ^{♦1)} (includes passenger’s airbag deactivation switch)	<input checked="" type="checkbox"/>	<input checked="" type="checkbox"/>
Airbag – Front seat mounted airbags ¹⁾ with air curtain restraint	<input checked="" type="checkbox"/>	<input checked="" type="checkbox"/>
Seat belts – 3-point diagonal inertia reel (all seats) ¹⁾	<input checked="" type="checkbox"/>	<input checked="" type="checkbox"/>
ISOFIX child seat – 4 attachments – Driver’s and passenger’s side (second and third row)	<input checked="" type="checkbox"/>	<input checked="" type="checkbox"/>
Alcohol Interlock Interface (Prep Pack)	<input checked="" type="checkbox"/>	<input checked="" type="checkbox"/>
SECURITY		
Alarm – Thatcham Category 1	<input type="checkbox"/>	<input checked="" type="checkbox"/>
Immobiliser – Passive Anti-Theft System (PATS) (insurance-approved Category 2 immobiliser)	<input checked="" type="checkbox"/>	<input checked="" type="checkbox"/>
Locks – Power door deadlocks, shielded with strengthened mountings	<input checked="" type="checkbox"/>	<input checked="" type="checkbox"/>
Locks – Remote control central locking with 2 key fobs	<input checked="" type="checkbox"/>	<input checked="" type="checkbox"/>
Locks – Configurable 1 press first row doors, 2 press all doors*	<input checked="" type="checkbox"/>	<input checked="" type="checkbox"/>
Locks – Audio mis-lock feedback, audible signal if a door is ajar when locking activated	<input checked="" type="checkbox"/>	<input checked="" type="checkbox"/>
Locks – Key-operated bonnet release	<input checked="" type="checkbox"/>	<input checked="" type="checkbox"/>
Locks – Anti-pick	<input type="checkbox"/>	<input type="checkbox"/>
Stolen vehicle recovery system	<input checked="" type="checkbox"/>	<input checked="" type="checkbox"/>
BRAKES		
Brakes – Anti-lock brake system (ABS), with Trailer Sway Control, Hill Start Assist (HSA) ²⁾ , Electronic Stability Control (ESC) ¹⁾ , Traction Control and Electric Brake Boost	<input checked="" type="checkbox"/>	<input checked="" type="checkbox"/>
Intersection Assist Level 2	<input checked="" type="checkbox"/>	<input checked="" type="checkbox"/>
Reverse Brake Assist	<input checked="" type="checkbox"/>	<input checked="" type="checkbox"/>

*For details of the configurations available, please consult your Ford Dealer. **Please note:** Configurable locking must be defined at the time of order, it cannot be ordered as a Dealer-fitted option or accessory. ♦**Note: A rear-facing child seat should never be placed in the front passenger seat when the Ford vehicle is equipped with an operational front passenger’s airbag.**¹⁾Safety feature, ²⁾Driver Assistance feature.

**Ford eCall shares vehicle location and helps the occupants initiate a call in their respective language to the local Communications Centre, following a vehicle crash event involving an airbag deployment or fuel pump shut off. The feature operates in more than 40 European countries and regions.

Standard Option, at extra cost Part of an option pack at extra cost.

4 SPECIFICATIONS

SAFETY AND SECURITY

	Zetec	Titanium
TECHNOLOGY		
e-Call**	<input checked="" type="checkbox"/>	<input checked="" type="checkbox"/>

*For details of the configurations available, please consult your Ford Dealer. **Please note:** Configurable locking must be defined at the time of order, it cannot be ordered as a Dealer-fitted option or accessory. **Note:** A rear-facing child seat should never be placed in the front passenger seat when the Ford vehicle is equipped with an operational front passenger's airbag. ¹⁾Safety feature, ²⁾Driver Assistance feature.

**Ford eCall shares vehicle location and helps the occupants initiate a call in their respective language to the local Communications Centre, following a vehicle crash event involving an airbag deployment or fuel pump shut off. The feature operates in more than 40 European countries and regions.

UTILITY

	Zetec	Titanium
BODY		
Doors – Dual sliding load doors	<input checked="" type="checkbox"/>	<input checked="" type="checkbox"/>
Doors – Glazed rear tailgate with wash/wipe	<input checked="" type="checkbox"/>	<input checked="" type="checkbox"/>
Side windows – Second row, flip-open	<input type="checkbox"/>	<input type="checkbox"/>
Side windows – Second row, fixed	<input checked="" type="checkbox"/>	<input checked="" type="checkbox"/>
Side windows – Third row, fixed	<input checked="" type="checkbox"/>	<input checked="" type="checkbox"/>
CARPET AND TRIM		
Floor covering – Carpet	<input checked="" type="checkbox"/>	<input checked="" type="checkbox"/>
Luggage compartment mat	<input type="checkbox"/>	<input type="checkbox"/>
Front carpet floor mats	<input type="checkbox"/>	<input type="checkbox"/>
ELECTRICAL		
Power point socket – 1 x 12 V (located on instrument panel)	<input checked="" type="checkbox"/>	<input checked="" type="checkbox"/>
Dual USB point (located on instrument panel)	<input checked="" type="checkbox"/>	<input checked="" type="checkbox"/>
Power point socket – 12 V (located in rear)	<input checked="" type="checkbox"/>	<input checked="" type="checkbox"/>
Rear single USB port	<input checked="" type="checkbox"/>	<input checked="" type="checkbox"/>
Rear triple USB ports	<input type="checkbox"/>	<input type="checkbox"/>

UTILITY

	Zetec	Titanium
EXTERIOR FUNCTIONAL		
Roof rack – Integrated and foldable	<input type="checkbox"/>	<input type="checkbox"/>
Tailgate bike carrier	<input type="checkbox"/>	<input type="checkbox"/>
Trailer tow medium duty	<input checked="" type="checkbox"/>	<input checked="" type="checkbox"/>
Fixed tow bar	<input type="checkbox"/>	<input type="checkbox"/>
Tyre carrier drop door open	<input checked="" type="checkbox"/>	<input checked="" type="checkbox"/>
LOADSPACE COMPARTMENT		
Load compartment – 2 x DIN 75410 compliant tie-down loops (L1 only)	<input checked="" type="checkbox"/>	<input checked="" type="checkbox"/>
Load compartment – 4 x DIN 75410 compliant tie-down loops (standard on L2, option on L1)	<input checked="" type="checkbox"/> / <input type="checkbox"/>	<input checked="" type="checkbox"/> / <input type="checkbox"/>

SPECIAL VEHICLE OPTIONS

	Zetec	Titanium
SPECIAL VEHICLE OPTIONS		
Engine rpm speed control (1300-3000)	<input type="checkbox"/>	<input type="checkbox"/>
Trailer tow electrics – Trailer tow electrics (connector and wiring) without the tow bar	<input type="checkbox"/>	<input type="checkbox"/>
Battery – Twin high-performance deep-cycle AGM batteries (Dual H8 AGM batteries)	<input type="checkbox"/>	<input type="checkbox"/>
Aux wiring	<input type="checkbox"/>	<input type="checkbox"/>
Smart fuse box – Mid-level	<input type="checkbox"/>	<input type="checkbox"/>
Taxi Prep Pack (WAV, floor covering – delete second row seating)	<input type="checkbox"/>	<input type="checkbox"/>
Taxi Prep Pack (WAV, no floor covering – delete second and third row seating)	<input type="checkbox"/>	<input type="checkbox"/>

Standard Option, at extra cost Part of an option pack at extra cost.

5

PURCHASE

Getting behind the wheel of your next new Ford is simple, with a variety of finance options.



BUILD YOUR VEHICLE

Build and personalise your vehicle online. Simply head to the Ford website, select your model, then choose your engine, body colour and extras. You'll be able to view the recommended price, and send your configuration to a Ford Dealer if you wish.

[LEARN MORE](#) 



FIND A DEALER AND REQUEST A TEST DRIVE

You can search for a Ford Dealer by location or Dealer name on the Ford website, and request a test drive online. Simply fill in your details and your chosen Dealer will contact you to arrange a convenient time.

[LEARN MORE](#) 

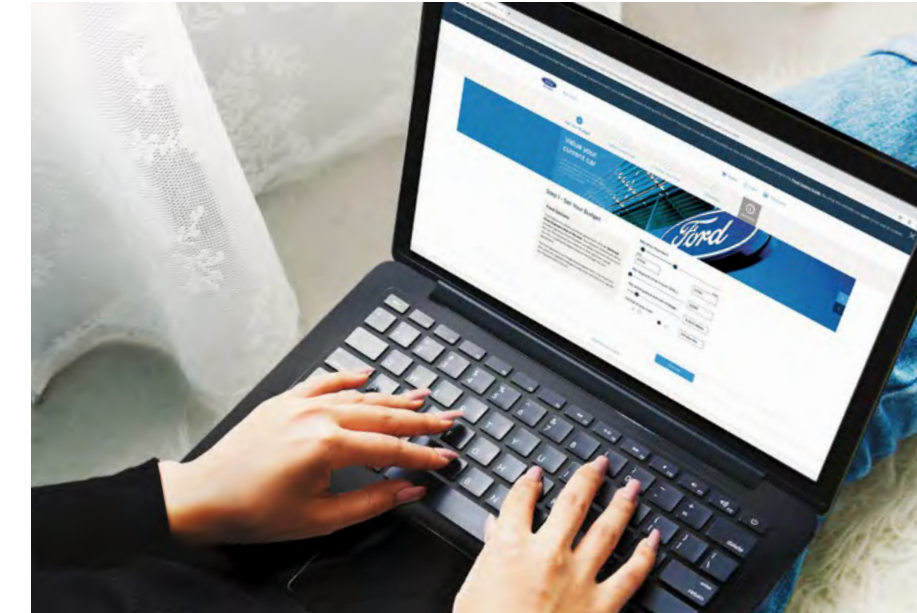

FINANCE

When it comes to financing your vehicle, our size and expertise means we're well placed to provide you with a wide range of finance products.

Ford Credit* provides a range of finance products for your vehicle whether you are a private or business user.

Ford Lease^ specialises in contract hire and leasing and provides an alternative range of finance plans which can be tailored to suit your business.

For more information about our finance products visit

[LEARN MORE](#) 

OWNERSHIP & PROTECT



FORD INSURE

Designed specifically for Ford owners, Ford Insure† offers value, simplicity and a range of benefits that really matter to you.

- Repairs by experts at one of our authorised Ford Repair Centres with a courtesy car provided while your car is being repaired
- Guaranteed repairs for as long as you own your Ford
- Genuine Ford Parts and manufacturer-spec glass
- For electric and hybrid vehicles, cover for accidental damage, fire and theft of battery and standard charging equipment (excluding wall box)
- Free 24 hour emergency help lines
- Named Drivers earn a Ford Insure No Claims Bonus which can be used on any Ford Insure car insurance policy

[LEARN MORE](#) 

*Finance subject to status. Guarantees may be required. Freepost Ford Credit.

Ford Credit is a trading style of FCE Bank plc. Which is authorised by the Prudential Regulation Authority and regulated by the Financial Conduct Authority and the Prudential Regulation Authority under firm reference number 204469.

^Ford Lease is provided by ALD Automotive Limited acting as Ford Lease BS16 7LB. ALD is registered in England No. 987418. ALD is authorised and regulated by the Financial Conduct Authority.

†Terms and conditions apply. Ford Insure contracts are arranged, administered and provided by EUI Limited. EUI Limited is a subsidiary of Admiral Group plc and is authorised and regulated by the Financial Conduct Authority (Firm reference number: 309378). Registered in England and Wales as EUI Limited Reg. No. 2686904 Registered Address: Ty Admiral, David Street, Cardiff CF10 2EH.

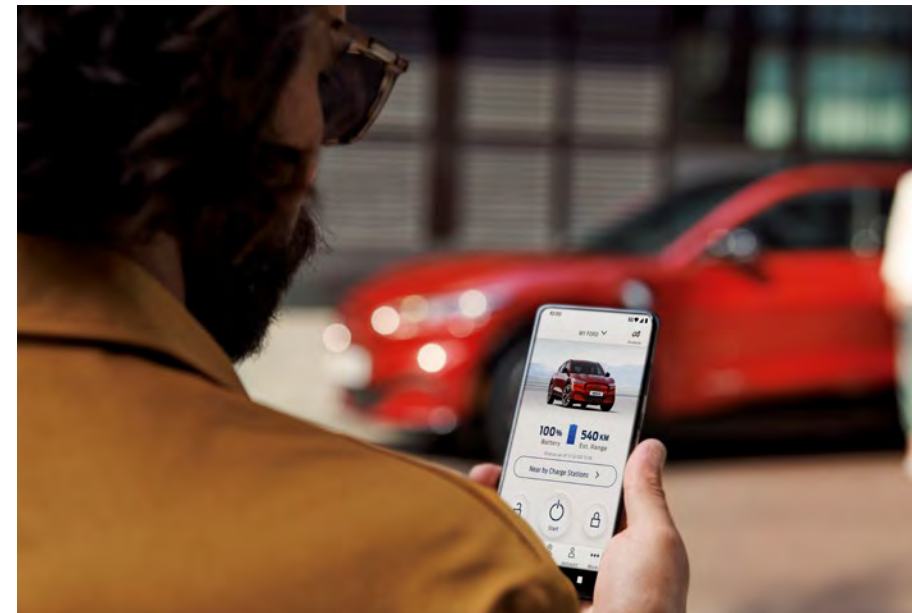

FORDPASS APP

Unlock your car's full potential with the FordPass app. FordPass seamlessly connects you with your vehicle, keeping you moving in intelligent, intuitive ways. From optimising the route of your journey, self-diagnosing and sending you vehicle health alerts, pre-heating your vehicle before you get in, to helping you find your way back to your parked car on a map. It even removes the worry of whether you locked your car, thanks to Remote Lock and Unlock.

[LEARN MORE](#)

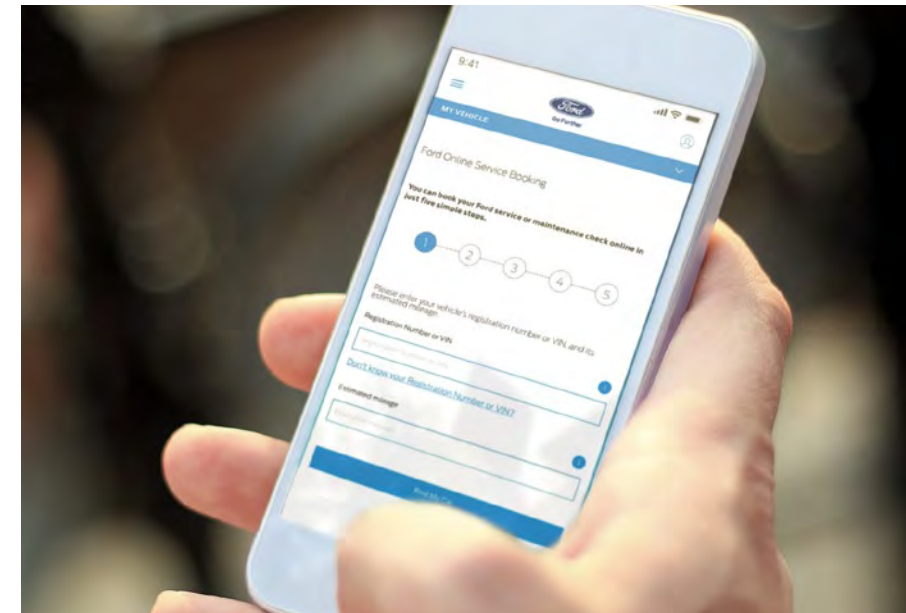

FORD SERVICE

With Ford, the service doesn't end when you leave the showroom. Ford Service is designed to keep your Ford in great condition and help you make the most of your car throughout its life.

- Ford Online Service Booking
- Contactless servicing options, for your convenience and safety
- Comprehensive service and maintenance plans
- Use of genuine Ford parts for added peace of mind
- Ford-trained technicians using the latest diagnostic equipment and tools
- One call for everything Ford 0203 564 4444
- Ford Accident Management, service free to all drivers
- Up to 12 months' UK and European Roadside Assistance (at participating Dealers)

[LEARN MORE](#)



FORD PROTECT

3 Year/60,000 miles warranty to 4 years/80,000 miles. Key benefits include*:

- High flexibility in duration and mileage
- Cover against unexpected electrical and mechanical repair costs in the UK and Europe
- The price of covered parts and labour are guaranteed for the length of your plan

Ford Protect New Vehicle Warranties are transferable to the new owner should you decide to sell your vehicle.

[LEARN MORE](#)



FORD PROTECT SERVICE PLANS

With various payment options available, you can cover the cost of your recommended scheduled services for up to 4 years from the day your new Ford is registered. This can work out cheaper than paying for individual services and gives you added benefits:

- Ford Assistance – your UK and European Roadside Assistance will be increased to the length of your plan
- Vehicle hire – in the event we can't finish any work covered by the plan within 24 hours, we'll lend you a courtesy car for up to 7 days**
- A full Ford Service History, which may enhance your car's resale value

[LEARN MORE](#)

*Ford Protect terms and conditions apply. Please call 03702 416 726.

**Subject to availability and status, excluding fuel and insurance costs.

5 PURCHASE

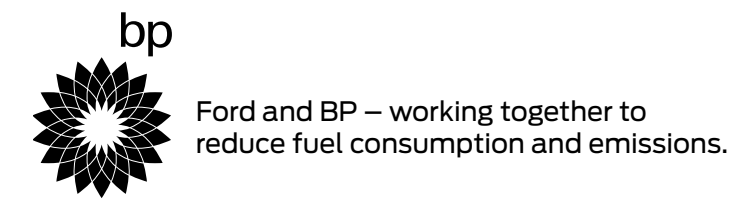

BOOK A TEST DRIVE TODAY

The best way to get acquainted with the capabilities and possibilities offered by the new Tourneo Custom range is with a test drive.

Book yours today, and your local Ford Dealer will be happy to assist you as soon as possible.

[CONTACT US NOW](#)



Illustrations, descriptions and specifications. This catalogue was correct at the time of going to print. However, Ford policy is one of continuous product development. The right is reserved to change specifications, colours and recommended prices of the models and items illustrated and described in this publication at any time. For the latest details always consult your Ford Dealer. **Optional equipment.** Throughout this publication, wherever a feature is described as being an 'Option' or 'Option Fitment/Pack' etc, you should assume that it will be at extra cost to the base vehicle, unless specifically stated to the contrary. All models and colour combinations are subject to availability. **Note.** Some images portrayed are of a pre-production model and/or are computer generated, therefore, the design/features on the final version of the vehicle may differ in various respects. In addition, some of the features shown on the vehicles may be optional. **Note.** This brochure contains both original Ford accessories as well as a range of products from our suppliers. Fitment of accessories may have an impact on your vehicle's fuel consumption. + The identified accessories are carefully selected third party supplier branded accessories which do not come with a Ford warranty but are covered by the third party supplier's own warranty, the details of which can be obtained from your Ford Dealer. **Note.** The Bluetooth® word mark and logos are owned by the Bluetooth SIG, Inc. and any use of such marks by Ford Motor Company is under licence. The iPod word mark and logos are the property of Apple Inc. Other trademarks and trade names are those of their respective owners. **Note.** Some driver assistance features and safety features described in this brochure are designed to function using sensors, whose performance may be affected under certain weather or environmental conditions.

The Government fuel figures do not express or imply any guarantee of the fuel consumption of any particular vehicle. The vehicles themselves have not been tested and there are inevitably differences between individual vehicles of the same model. In addition, a vehicle may incorporate particular modifications. Furthermore, the driver's style and road and traffic conditions, as well as the extent to which the vehicle has been driven and the standard of maintenance, will affect its fuel consumption. **Insurance groups** are only as recommended by the Association of British Insurers. You should always consult your insurance adviser for confirmation.

Ford One Call

In the unlikely event that your Ford Dealer can't help you or if you need to speak to us directly, call 0203 564 4444

Ford Rental – local service nationwide

Car and Van rental from our latest model range. Contact your local Ford Dealer for more information

Ford Motability

Call our Ford Motability team on 0345 6040019

Finance

Ford Credit Customer Services 0345 712 5490.

Ford Lease Customer Services 0344 600 1405

Calls to 0344 and 0345 numbers are charged at the same rate as a standard 01 or 02 geographic number, even when calling from a mobile.

Published by Ford Motor Company Limited, Laindon, Essex, England. Registered in England No. 235446. © Ford Motor Company Limited.