



FORD COMPONENT SALES

2.3L GTDI EcoBoost Engine in the Ranger

Technical Specifications

Engine Type: 2.3 GTDI
EcoBoost

Block / Head: Aluminium /
Aluminium

Bore x Stroke (in):
3.4449(87.5mm) x 3.7008
(94mm)

Displacement (litres / cu. in):
2.3L/140

Main Bearings: 10

Compression Ratio: 10 : 1

Fuel Injection: TIVCT

Valve Operation: DOHC

Power (HP @ RPM): 270 @
5,500RPM

Torque (lb.- t @ RPM): 310 @
3000RPM

Oil Capacity/Spec: 6.2 Qts /
SAE 5W-30

Weight (kg): 145
(Engine as shipped)

Dimensions (mm) H x W x L:
855 x 564 x 633

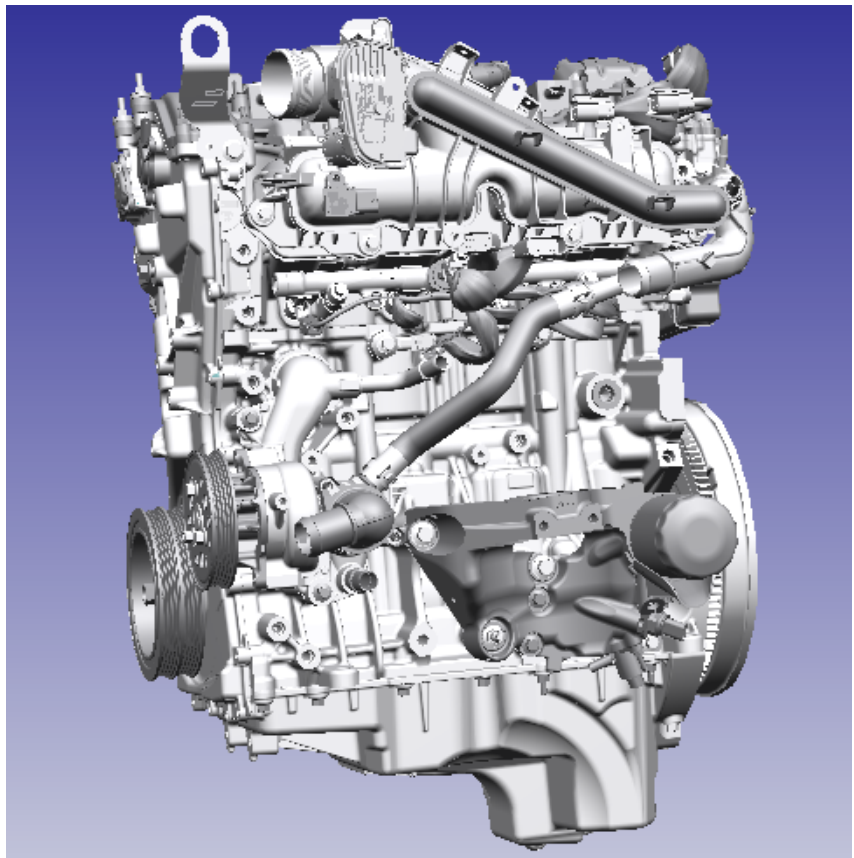

[fordcomponentsales](http://fordcomponentsales.com)

Dunton Technical Centre,
Arterial Road, Laindon, Essex, SS15 6EE

 fcseuqry@ford.com

2.3L GTDI EcoBoost Engine in the Ranger

Key Feature and Benefits

Composite intake manifold

Dual Overhead Camshafts

Independent variable camshaft timing(Ti-VCT)

Specifications, features, and benefits applicable to engines and transmissions are based on Ford products, and may vary with different applications. Pictures and details shown are for illustrative purposes only (actual product may vary). Additionally, the availability of the product(s) described herein may vary. Contact Ford Component Sales, for details.